

HS27 SERIES UNITS

The HS27 is a 14 SEER high efficiency residential split system condensing unit which features a scroll compressor. It operates much like a standard condensing unit, but the HS27's scroll compressor is unique in the way that it compresses refrigerant. Several models are available in sizes ranging from 2 through 3.5 tons. The series is designed for use with an expansion valve in the indoor unit.

This manual is divided into sections which discuss the major components, refrigerant system, charging procedure, maintenance and operation sequence.

All specifications in this manual are subject to change.

**ELECTROSTATIC DISCHARGE (ESD)
Precautions and Procedures**

⚠ CAUTION

Electrostatic discharge can affect electronic components. Take precautions during unit installation and service to protect the unit's electronic controls. Precautions will help to avoid control exposure to electrostatic discharge by putting the unit, the control and the technician at the same electrostatic potential. Neutralize electrostatic charge by touching hand and all tools on an unpainted unit surface before performing any service procedure.



⚠ WARNING

Refrigerant can be harmful if it is inhaled. Refrigerant must be used and recovered responsibly. Failure to follow this warning may result in personal injury or death.

SPECIFICATIONS

Model No.			HS27-024	HS27-030	HS27-036	HS27-042
Condenser Coil	Net face area — sq. ft. (m ²)	Outer coil	16.04 (1.49)	16.04 (1.49)	21.77 (2.02)	21.77 (2.02)
		Inner coil	13.33 (1.24)	13.33 (1.24)	21.11 (1.96)	21.11 (1.96)
	Tube diameter — in. (mm)		5/16 (8)	5/16 (8)	5/16 (8)	5/16 (8)
	No. of rows		2	2	2	2
	Fins per inch (m)		22 (866)	22 (866)	22 (866)	22 (866)
Condenser Fan	Dia. - in. (mm) no. of blades		24 (610) - 3	24 (610) - 3	24 (610) - 3	24 (610) - 3
	Motor hp (W)		1/10 (75)	1/10 (75)	1/6 (124)	1/6 (124)
	Cfm (L/s)		2500 (1180)	2500 (1180)	3000 (1415)	3000 (1415)
	Rpm		825	825	825	825
	Watts		165	165	210	210
*Refrigerant — HCFC-22 charge furnished			6 lbs. 10 oz. (3.0 kg)	6 lbs. 6 oz. (2.9 kg)	9 lbs. 15 oz. (4.5 kg)	9 lbs. 15 oz. (4.5 kg)
Liquid line (o.d.) — in. (mm) sweat			3/8 (9.5)	3/8 (9.5)	3/8 (9.5)	3/8 (9.5)
Suction line (o.d.) in. — (mm) sweat			3/4 (19)	3/4 (19)	7/8 (22.2)	7/8 (22.2)
Shipping weight — lbs. (kg) 1 package			221 (100)	221 (100)	267 (121)	267 (121)

*Refrigerant charge sufficient for 15 ft. (4.5 m) length of refrigerant lines.

ELECTRICAL DATA

Model No.		HS27-024	HS27-030	HS27-036	HS27-042
Line voltage data — 60hz		208/230v 1ph	208/230v 1ph	208/230v 1ph	208/230v 1ph
Compressor	Rated load amps	10.3	12.2	13.5	16.5
	Power factor	.96	.96	.96	.97
	Locked rotor amps	56	61	73	95
Condenser Coil Fan Motor	Full load amps	0.9	0.9	1.0	1.0
	Locked rotor amps	1.6	1.6	2.5	2.5
Rec. max. fuse or circuit breaker size (amps)		20	25	30	35
*Minimum circuit ampacity		13.8	16.2	17.9	21.6

*Refer to National or Canadian Electrical Code manual to determine wire, fuse and disconnect size requirements.
NOTE — Extremes of operating range are plus 10% and minus 5% of line voltage.

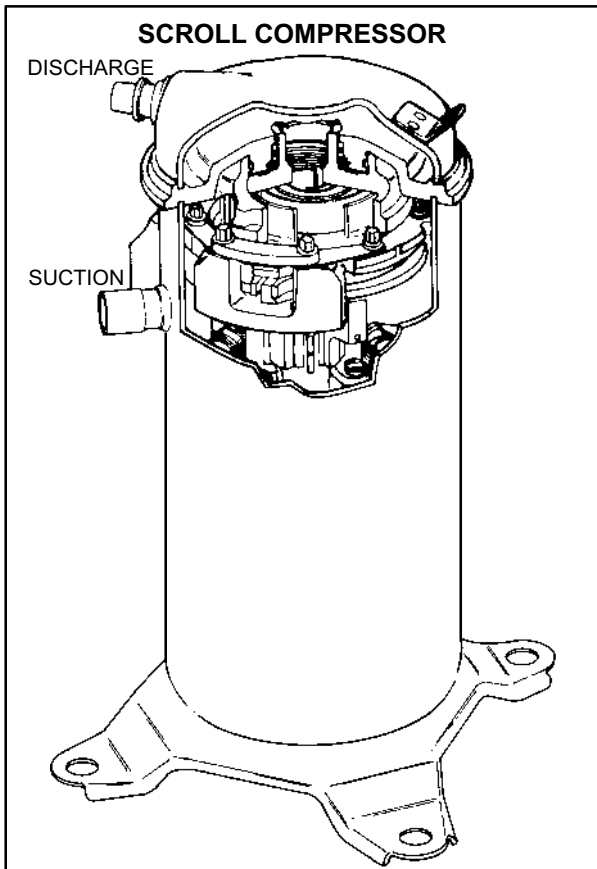

FIGURE 1

I-APPLICATION

All major components (indoor blower/coil) must be matched according to Lennox recommendations for the compressor to be covered under warranty. Refer to the Engineering Handbook for approved system matchups. A misapplied system will cause erratic operation and can result in early compressor failure.

II-SCROLL COMPRESSOR

The scroll compressor design is simple, efficient and requires few moving parts. A cutaway diagram of the scroll compressor is shown in figure 1. The scrolls are located in the top of the compressor can and the motor is located just below. The oil level is immediately below the motor.

The scroll is a simple compression concept centered around the unique spiral shape of the scroll and its inherent properties. Figure 2 shows the basic scroll form. Two identical scrolls are mated together forming concentric spiral shapes (figure 3). One scroll remains stationary, while the other is allowed to "orbit" (figure 4). Note that the orbiting scroll does not rotate or turn but merely "orbits" the stationary scroll.

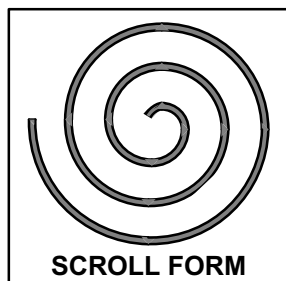

FIGURE 2

NOTE - During operation, the head of a scroll compressor may be hot since it is in constant contact with discharge gas.

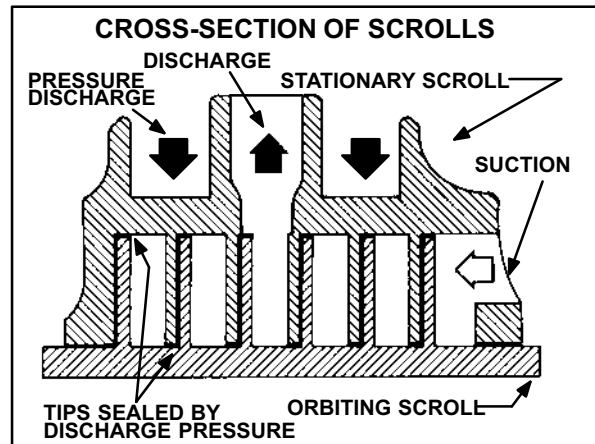

FIGURE 3

The counterclockwise orbiting scroll draws gas into the outer crescent shaped gas pocket created by the two scrolls (figure 4 - 1). The centrifugal action of the orbiting scroll seals off the flanks of the scrolls (figure 4 - 2). As the orbiting motion continues, the gas is forced toward the center of the scroll and the gas pocket becomes compressed (figure 4 - 3). When the compressed gas reaches the center, it is discharged vertically into a chamber and discharge port in the top of the compressor (figure 1). The discharge pressure forcing down on the top scroll helps seal off the upper and lower edges (tips) of the scrolls (figure 3). During a single orbit, several pockets of gas are compressed simultaneously providing smooth continuous compression.

The scroll compressor is tolerant to the effects of liquid return. If liquid enters the scrolls, the orbiting scroll is allowed to separate from the stationary scroll. Continued slugging of liquid will cause damage to the scroll and replacement will be necessary. The liquid is worked toward the center of the scroll and is discharged. If the compressor is replaced, conventional Lennox clean-up practices must be used.

Due to its efficiency, the scroll compressor is capable of drawing a much deeper vacuum than reciprocating compressors. Deep vacuum operation can cause internal fusite arcing resulting in damaged internal parts and will result in compressor failure. Never use a scroll compressor for evacuating or "pumping-down" the system. This type of damage can be detected and will result in denial of warranty claims.

Compressors on HS27 units feature a mechanical anti-rotational device (AREST) which prevents backward rotation due to thermostat cycling or power interruption. The compressor is also equipped with a discharge thermostat limit and pressure relief valve, which opens at approximately 450 psig above suction pressure. All features are internal and are not field replaceable.

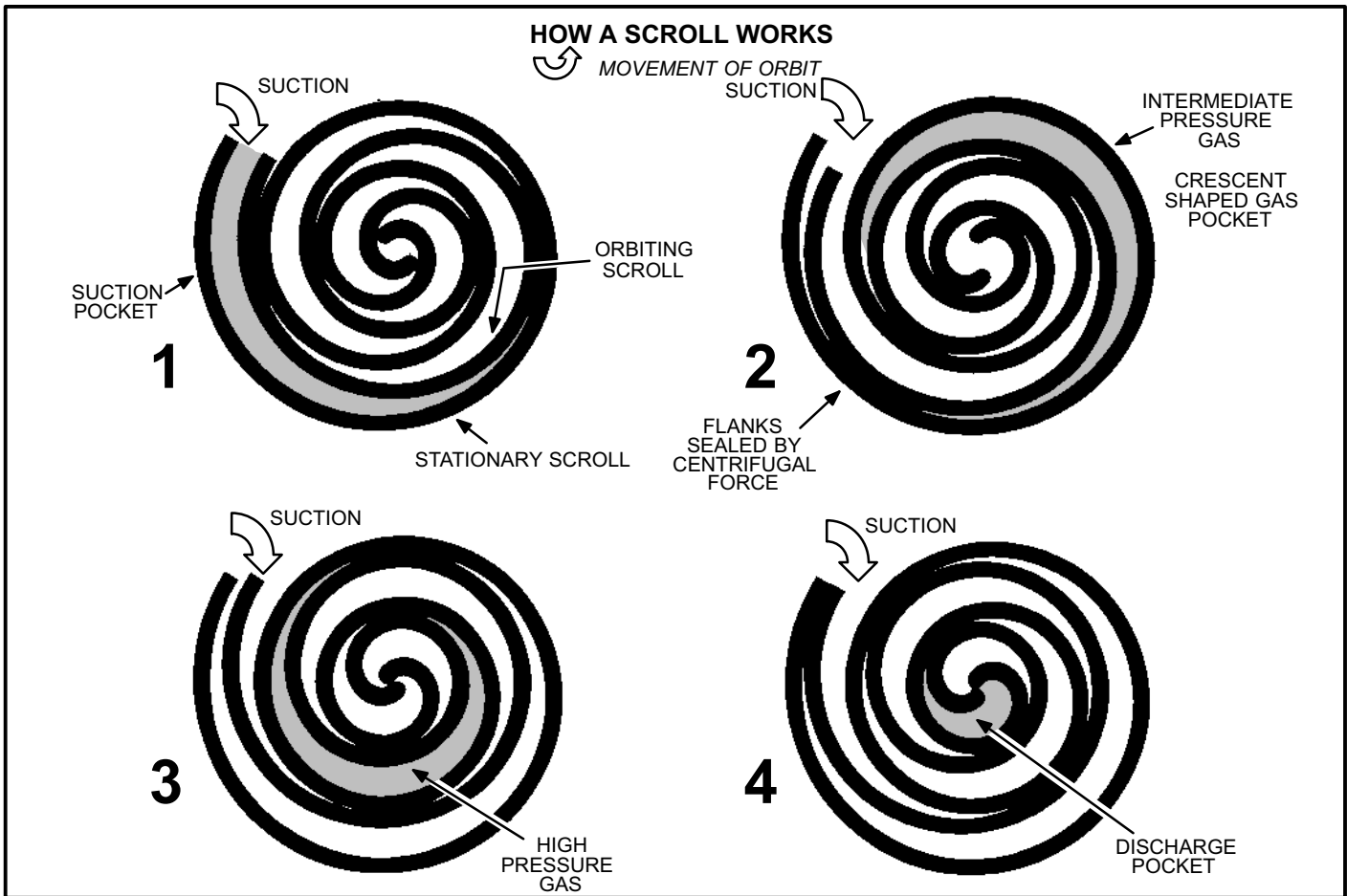

FIGURE 4

III-UNIT COMPONENTS

A-Transformer

The contactor coil and timed off control are all energized by 24VAC supplied by the indoor unit. All other controls in the outdoor unit are powered by line voltage. Refer to unit wiring diagram. The HS27 is **not equipped** with an internal line voltage to 24V transformer.

B-Contactor

The compressor is energized by a contactor located in the control box. All HS27-1 units use DPST contactors. All HS27-2 and later units use single-pole contactors. The contactor is energized by indoor thermostat terminal Y when thermostat demand is present.

C-TOC Timed Off Control

Some HS27 units (see wiring diagrams) are equipped with a TOC, timed off control. The TOC is located in the control box (figure 5). The time delay is electrically connected between thermostat terminal Y and the compressor contactor. Between cycles, the compressor contactor is delayed for 5 minutes \pm 2 minutes. At the end of the delay, the compressor is allowed to energize. When thermostat demand is satisfied, the time delay opens the circuit to the compressor contactor coil and the compressor is de-energized. Without the time delay it would be possible to short cycle the compressor. A scroll compressor, when short cycled, can run backward if head pressure is still high. It does not harm a scroll compressor to run backward, but it could cause a nuisance tripout of safety limits. For this reason, if a TOC fails it must be replaced.

NOTE: Do not attempt to repair the timed off control. Unsafe operation will result. If the TOC is found to be inoperative, simply replace it.

⚠ DANGER

Electric Shock Hazard.
May cause injury or death.

Disconnect all remote electrical power supplies before opening unit panel. Unit may have multiple power supplies.

Some units are equipped with single-pole contactors. When unit is equipped with a single-pole contactor, line voltage is present at all components (even when unit is not in operation).

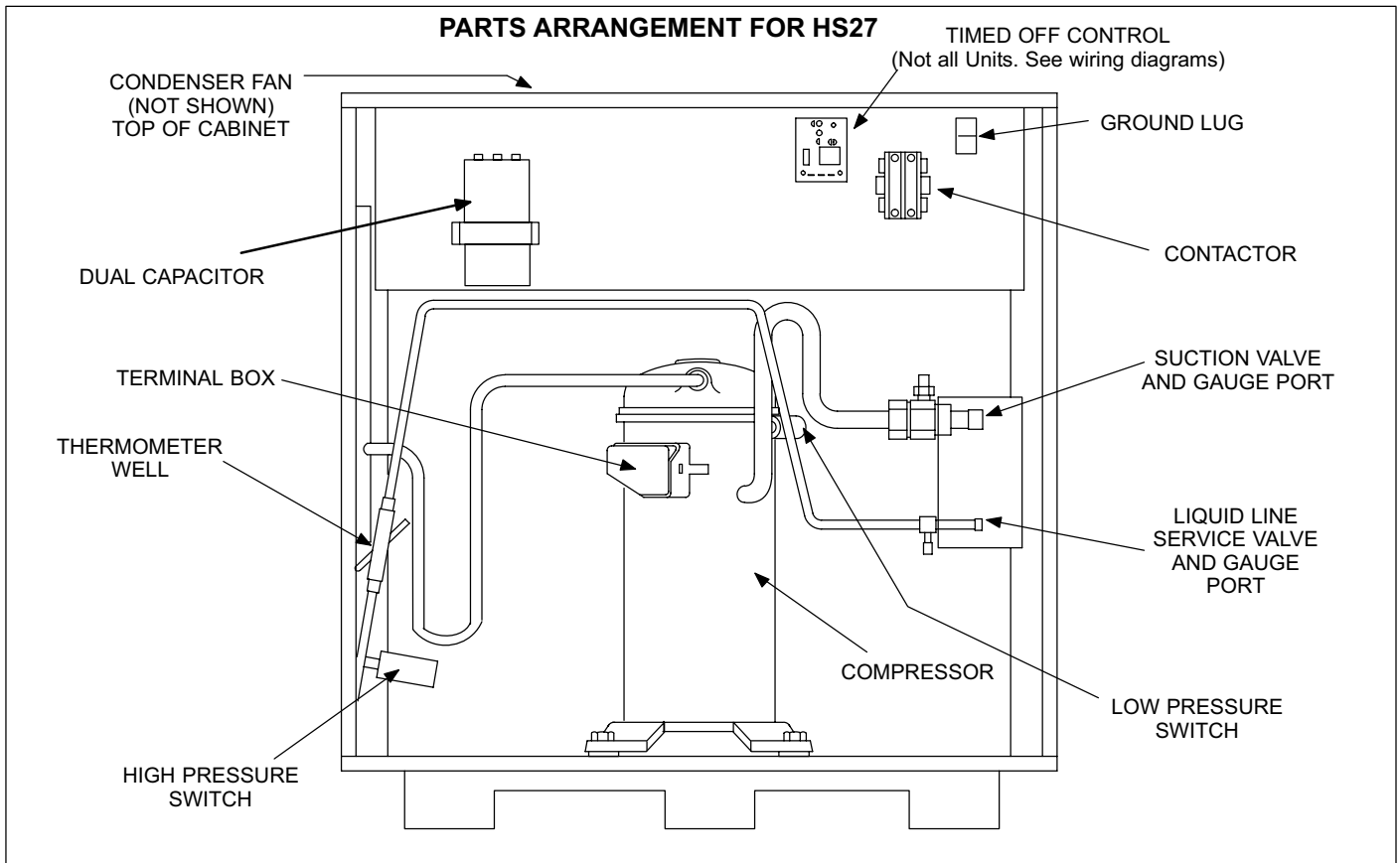

FIGURE 5

D-Compressor

Table 1 shows the specifications of compressors used in HS27 series units.

TABLE 1

Unit	Vac	Phase	LRA	RLA	Oil fl.oz.
HS27-024	208/230	1	56	10.3	38
HS27-030	208/230	1	61	12.2	42
HS27-036	208/230	1	73	13.5	42
HS27-042	208/230	1	95	16.5	42

*Shipped with conventional white oil (Sontex 200LT). 3GS oil may be used if additional oil is required.

E-High Pressure Switch

A manual-reset single-pole single-throw high pressure switch located in the liquid line of the compressor shuts off the compressor when liquid line pressure rises above the factory setting. The switch is normally closed and is permanently adjusted to trip (open) at 410 ± 10 psi. See figure 5 for switch location.

F-Low Pressure Switch

An auto-reset single-pole single-throw low pressure switch located in the suction line of the compressor shuts off the compressor when suction pressure drops below the factory setting. The switch is normally closed and is permanently adjusted to trip (open) at 25 ± 5 psi. The switch automatically resets when suction line pressure rises above 55 ± 5 psi. See figure 5 for switch location.

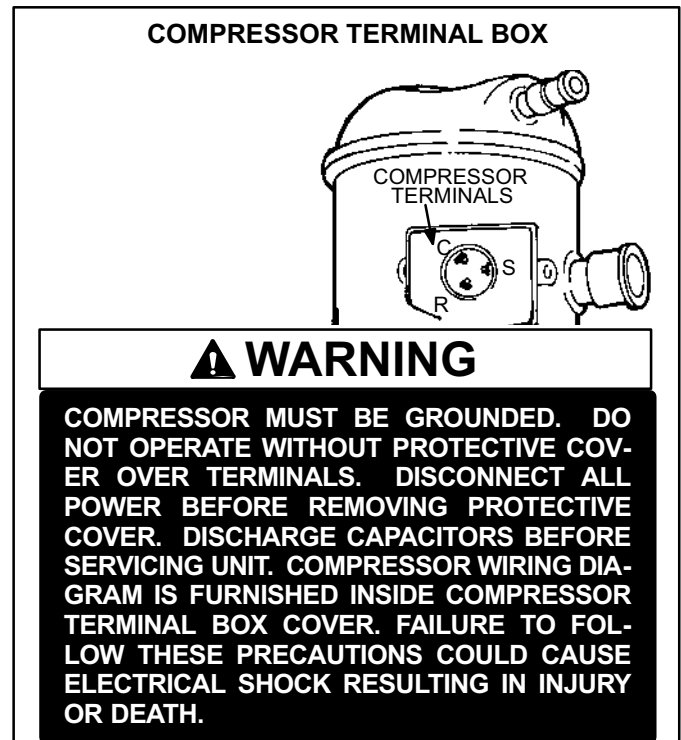

FIGURE 6

G-Dual Capacitor

The compressor and fan in HS27 single phase series units use permanent split capacitor motors. A single “dual” capacitor is used for both the fan motor and the compressor (see unit wiring diagram). The fan side of the capacitor and the compressor side of the capacitor have different mfd ratings. The capacitor is located inside the unit control box (see figure 5). Table 2 shows the ratings of the dual capacitor.

TABLE 2

HS27 DUAL CAPACITOR RATING			
UNITS	FAN MFD	HERM MFD	VAC
HS27-024	4	40	370
HS27-030	4	40	370
HS27-036	5	45	370
HS27-042	5	50	370

H--Condenser Fan Motor

All units use single-phase PSC fan motors which require a run capacitor. The “FAN” side of the dual capacitor is used for this purpose. The specifications table on page 1 of this manual shows the specifications of outdoor fans used in HS27s. In all units, the outdoor fan is controlled by the compressor contactor. See figure 7 if condenser fan motor replacement is necessary.

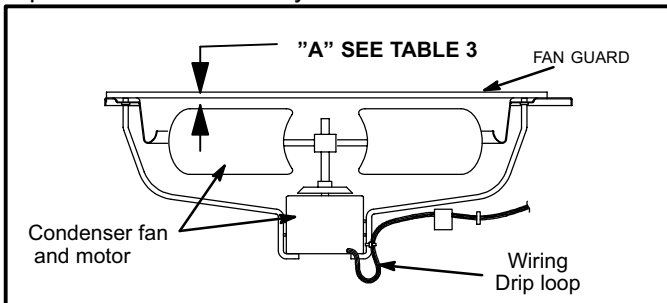

FIGURE 7

TABLE 3

UNIT	”A” DIM.	TOLERANCE
HS27-024, -030	1 1/16”	± 1/8”
HS27-036, -042	1 3/16”	± 1/8”

IV-REFRIGERANT SYSTEM

A-Plumbing

TABLE 4
REFRIGERANT LINE KITS

HS27 UNIT	LIQUID LINE	SUCTION LINE	L10 LINE SETS	L15 LINE SETS
-024 -030	3/8 in (10 mm)	3/4 in. (19 mm)	L10-41 20 ft. - 50 ft. (6 m - 15 m)	L15-41 15 ft. - 50 ft. (4.5 m - 15 m)
-036 -042	3/8 in (10 mm)	7/8 in. (22 mm)	L10-65 30 ft. - 50 ft. (9 m - 15 m)	L15-65 15 ft. - 50 ft. (4.5 m - 15 m)

Field refrigerant piping consists of liquid and suction lines from the outdoor unit (sweat connections). Use Lennox L10 or L15 series line sets as shown in table 4 or field-fabricated refrigerant lines. Refer to the piping section of the Lennox Service Unit Information Manual (SUI-803-L9) for proper size, type and application of field-fabricated lines.

Separate discharge and suction service ports are provided at the compressor for connection of gauge manifold during charging procedure.

B-Service Valves

The liquid line and suction line service valves and gauge ports are accessible by removing the compressor access cover. Full service liquid and suction line valves are used. See figures 8 and 9. The service ports are used for leak testing, evacuating, charging and checking charge. Service valves have a factory installed schrader valve. A service port cap is supplied to protect the schrader valve from contamination and assure a leak free seal. Valves are not reworkable. If a valve has failed it must be replaced.

To Access Schrader Port:

- 1- Remove service port cap with an adjustable wrench.
- 2- Connect gauge to the service port.
- 3- When testing is completed, replace service port cap. Tighten finger tight, then an additional 1/6 turn.

To Open Liquid or Suction Line Service Valve:

- 1- Remove stem cap with an adjustable wrench.
- 2- Using service wrench and 5/16” hex head extension back the stem out counterclockwise until the valve stem just touches the retaining ring.
- 3- Replace stem cap and tighten finger tight, then tighten an additional 1/6 turn.

⚠ DANGER

Do not attempt to backseat this valve. Attempts to backseat this valve will cause snap ring to explode from valve body under pressure of refrigerant. Personal injury and unit damage will result.

To Close Liquid or Suction Line Service Valve:

- 1- Remove stem cap with an adjustable wrench.
- 2- Using service wrench and 5/16” hex head extension, turn stem clockwise to seat the valve. Tighten firmly.
- 3- Replace stem cap. Tighten finger tight, then tighten an additional 1/6 turn.

NOTE: Stem cap is the primary seal and must be replaced. Always keep stem cap clean.

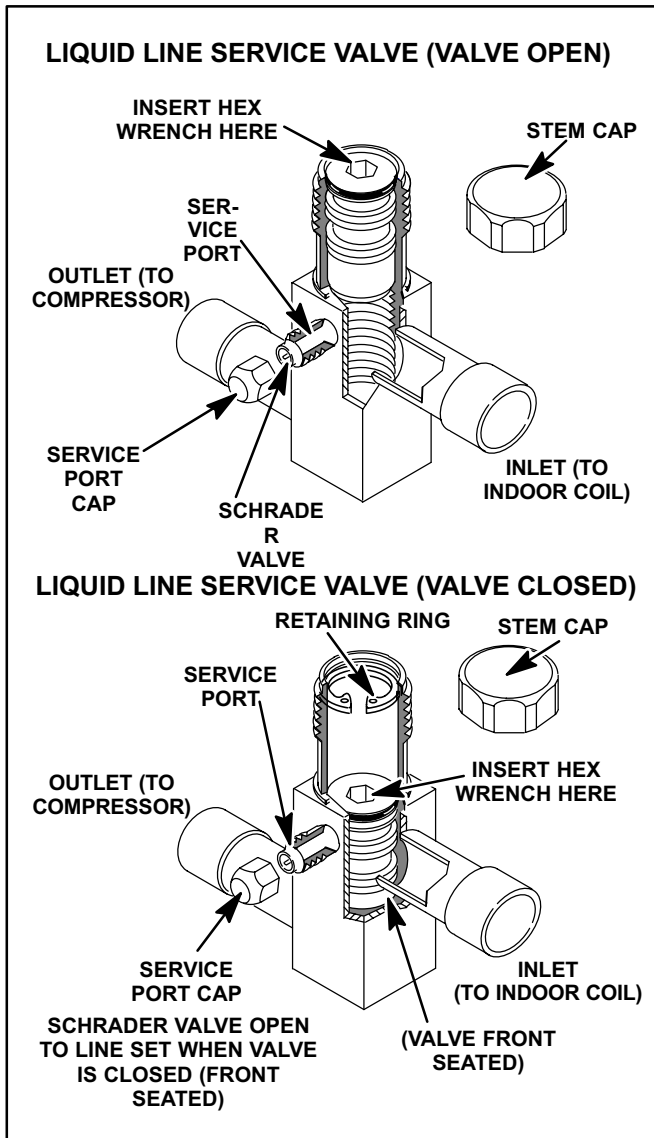

FIGURE 8

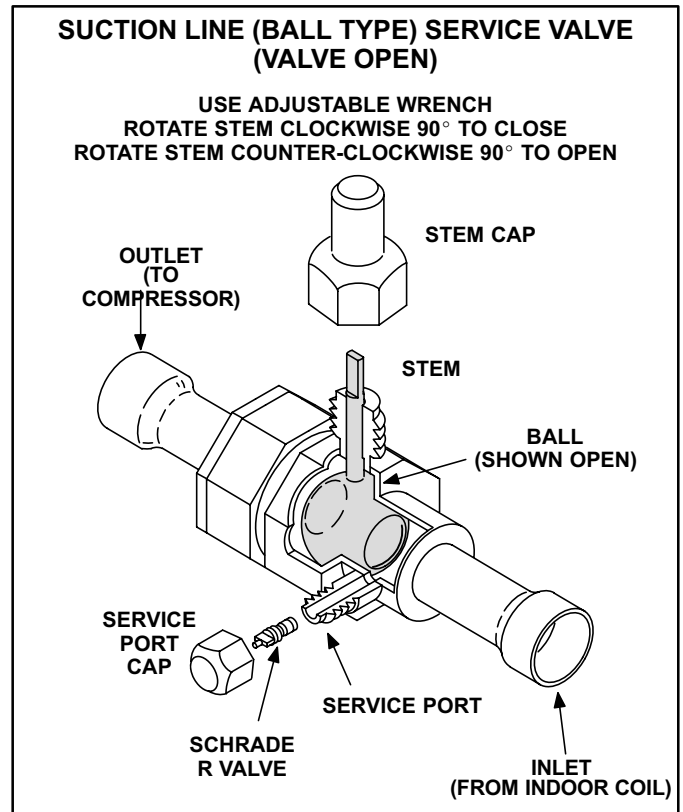

FIGURE 9

V-CHARGING

The unit is factory-charged with the amount of R-22 refrigerant indicated on the unit rating plate. This charge is based on a matching indoor coil and outdoor coil with a 15 foot (4.5m) line set. For varying lengths of line set, refer to table 5 for refrigerant charge adjustment. A blank space is provided on the unit rating plate to list actual field charge.

⚠ IMPORTANT

If line length is greater than 15 feet (4.5m), add the amount of refrigerant listed in table 4. If line length is less than 15 feet (4.5m), subtract this amount.

TABLE 5

Liquid Line Set Diameter	Ozs. per 5 ft. (g per 1.5m) adjust from 15 ft. (4.5m) line set*
3/8 in. (9.5mm)	3 ounces per 5 ft. (88.05g per 1.5m)

*If line length is greater than 15 ft. (4.56 m), add this amount. If line length is less than 15 ft. (4.5 m), subtract this amount.

Units are designed for line sets up to 50ft.(15.24m) Consult Lennox Refrigerant Piping Manual for line sets over 50 ft.(15.24m).

A-Leak Testing

- 1- Attach gauge manifold and connect a drum of dry nitrogen to center port of gauge manifold.
- 2- Add a small amount of refrigerant to the lines and coil. Open high pressure valve on gauge manifold and pressurize line set and indoor coil to 150 psig (1034 kPa).

WARNING



Danger of Explosion.
Can cause injury, death and equipment damage.
When using dry nitrogen, use a pressure-reducing regulator, set at 150 psig (1034 kPa) or less to prevent excessive pressure.

- 3- Check lines and connections for leaks.
NOTE-If electronic leak detector is used, add a trace of refrigerant to nitrogen for detection by leak detector.
- 4- Release nitrogen pressure from the system, correct any leaks and recheck.

B-Evacuating the System

Evacuating the system of non-condensables is critical for proper operation of the unit. Non-condensables are defined as any gas that will not condense under temperatures and pressures present during operation of an air conditioning system. Non-condensables such as water vapor, combine with refrigerant to produce substances that corrode copper piping and compressor parts.

- 1- Attach gauge manifold and connect vacuum pump (with vacuum gauge) to center port of gauge manifold. With both gauge manifold service valves open, start pump and evacuate evaporator and refrigerant lines.

IMPORTANT

A temperature vacuum gauge, mercury vacuum (U-tube), or thermocouple gauge should be used. The usual Bourdon tube gauges are not accurate enough in the vacuum range.

IMPORTANT

The compressor should never be used to evacuate a refrigeration or air conditioning system.

CAUTION

Danger of Equipment Damage. Avoid deep vacuum operation. Do not use compressors to evacuate a system. Extremely low vacuums can cause internal arcing and compressor failure. Damage caused by deep vacuum operation will void warranty.

- 2- Evacuate the system to an **absolute** pressure of .92 inches (23 mm) of mercury, or 23,000 microns.
- 3- After system has been evacuated to an absolute pressure of .92 inches (23 mm) of mercury, or 23,000 microns, close manifold valve to center port.
- 4- Stop vacuum pump and disconnect from gauge manifold. Attach a drum of dry nitrogen to center port of gauge manifold, open drum valve slightly to purge line, then break vacuum in system to 3 psig (20.7 kPa) pressure by opening manifold high pressure valve to center port.
- 5- Close nitrogen drum valve, disconnect drum from manifold center port and release nitrogen pressure from system.
- 6- Reconnect vacuum pump to manifold center port hose. Evacuate the system to an absolute pressure less than .197 inches (5 mm) of mercury, or 500 microns, then turn off vacuum pump. If the absolute pressure rises above .197 inches (5 mm) of mercury, or 5000 microns within a 20-minute period after stopping vacuum pump, repeat step 6. If not, evacuation is complete.
This evacuation procedure is adequate for a new installation with clean and dry lines. If excessive moisture is present, the evacuation process may be required more than once.
- 7- After evacuation has been completed, close gauge manifold service valves. Disconnect vacuum pump from manifold center port and connect refrigerant drum. Pressurize system slightly with refrigerant to break vacuum.

C-Charging

If the system is completely void of refrigerant, the recommended and most accurate method of charging is to weigh the refrigerant into the unit according to the total amount shown on the unit nameplate. Also refer to the SPECIFICATIONS table on page 1.

If weighing facilities are not available or if unit is just low on charge, the following procedure applies.

The following procedures are intended as a general guide for use with expansion valve systems only. For best results, indoor temperature should be between 70 °F and 80 °F (21°C and 26°C). Outdoor temperature should be 60 °F (15.5°C) or above. Slight variations in charging temperature and pressure should be expected. Large variations may indicate a need for further servicing.

⚠ IMPORTANT

Use table 8 as a general guide for performing maintenance checks. Table 8 is not a procedure for charging the system. Minor variations in these pressures may be expected due to differences in installations. Significant deviations could mean that the system is not properly charged or that a problem exists with some component in the system. Used prudently, table 8 could serve as a useful service guide.

APPROACH METHOD (TXV SYSTEMS) (Ambient Temperature of 60°F [16°C] or Above)

- 1- Connect gauge manifold. Connect an upright HCFC-22 drum to center port of gauge manifold.

⚠ IMPORTANT

The following procedure requires accurate readings of ambient (outdoor) temperature, liquid temperature and liquid pressure for proper charging. Use a thermometer with accuracy of +2 °F and a pressure gauge with accuracy of ±5 PSIG.

- 2- Record outdoor air (ambient) temperature.
- 3- Operate indoor and outdoor units in cooling mode. Allow units to run until system pressures stabilize.
- 4- Make sure thermometer well is filled with mineral oil before checking liquid line temperature.
- 5- Place thermometer in well and read liquid line temperature. Liquid line temperature should be a few degrees warmer than the outdoor air temperature. Table 6 shows how many degrees warmer the liquid line temperature should be.

Add refrigerant to make the liquid line cooler.
Recover refrigerant to make the liquid line warmer.

**TABLE 6
APPROACH METHOD FOR TXV SYSTEMS**

APPROACH TEMPERATURE LIQUID LINE °F (°C) - OUTDOOR AMBIENT °F (°C)			
HS27-024	HS27-030	HS27-036	HS27-042
5 ± 1 (3 ± .5)	5 ± 1 (3 ± .5)	6 ± 1 (3.3 ± .5)	7 ± 1 (3.9 ± .5)

Note-For best results, the same thermometer should be used to check both outdoor ambient and liquid temperatures.

- 6- When unit is properly charged, liquid line pressures should approximate those in table 8.

The Subcooling Method (TXV SYSTEMS) (Ambient Temperature of 60° F [16°C] or Less)

Because the outdoor ambient temperature is below 60°F, airflow over the outdoor coil will need to be reduced to drive up the liquid line pressure to a range of 200 - 250 psig. To do this block off the outdoor coil with cardboard or a plastic sheet. (Figure 10)

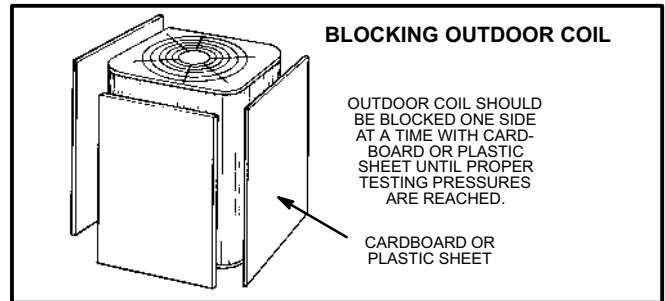

FIGURE 10

- 1- Remove the cap from the liquid line service valve stem and turn the stem clockwise 1/4 to 1/2 turn. This will open the service port.
- 2- With the manifold gauge hose still on the liquid service port and the unit operating, read the liquid line pressure.
- 3- If the pressure is too low, block the airflow through the outdoor coil until the liquid line pressure stabilizes in a range of 200 to 250 psig. At that time, record the liquid line temperature and the liquid line pressure reading.
- 4- Using a temperature/pressure chart for R22, determine the saturation temperature for the liquid line pressure reading.
- 5- Subtract the liquid line temperature from the saturation temperature (according to the chart) to determine Subcooling. **(Liquid line temperature - Saturation temperature = Subcooling)**
- 6- Compare the Subcooling value with those in table 7. If Subcooling is greater than shown, refrigerant must be reclaimed. If Subcooling is less than shown, refrigerant must be added.

**TABLE 7
SUBCOOLING METHOD LESS THAN 60°F**

MODEL	SUBCOOLING TEMP. °F ± 2° (1.1°C)
HS27-024	7 (3.8)
HS27-030	8 (4.4)
HS27-036	7 (3.8)
HS27-042	8 (4.4)

D-Oil Charge

Refer to Table 1 on Page 5.

VI-MAINTENANCE

⚠ WARNING	
	Electric shock hazard. Can cause injury or death. Before attempting to perform any service or maintenance, turn the electrical power to unit OFF at disconnect switch(es). Unit may have multiple power supplies.

At the beginning of each heating or cooling season, the system should be cleaned as follows:

A-Outdoor Unit

- 1- Clean and inspect condenser coil. (Coil may be flushed with a water hose).
- 2- Visually inspect all connecting lines, joints and coils for evidence of oil leaks.

⚠ IMPORTANT
If insufficient heating or cooling occurs, the unit should be gauged and refrigerant charge checked.

B-Indoor Coil

- 1- Clean coil if necessary.
- 2- Check connecting lines and coil for oil leaks.
- 3- Check condensate line and clean if necessary.

C-Indoor Unit

- 1- Clean or change filters.
 - 2- Adjust blower cooling speed. Check static pressure drop over coil to determine correct blower CFM. Refer to Lennox Engineering Handbook.
 - 3- Belt Drive Blowers - Check condition/tension.
 - 4- Check all wiring for loose connections.
 - 5- Check for correct voltage at unit.
 - 6- Check amp-draw on blower motor.
- Unit nameplate _____ Actual _____.

**TABLE 8
NORMAL OPERATING PRESSURES**

OUT-DOOR TEMP. (°F)	HS27-024		HS27-030		HS27-036		HS27-042	
	Liq. ± 10 psig	Suct. ± 5 psig	Liq. ± 10 psig	Suct. ± 5 psig	Liq. ± 10 psig	Suct. ± 5 psig	Liq. ± 10 psig	Suct. ± 5 psig
65	143	76	139	72	138	70	141	74
75	168	77	163	73	164	71	166	75
85	196	78	191	74	192	72	186	76
95	226	79	223	76	223	73	227	78
105	260	80	255	77	256	75	261	79

VII- Unit Diagram

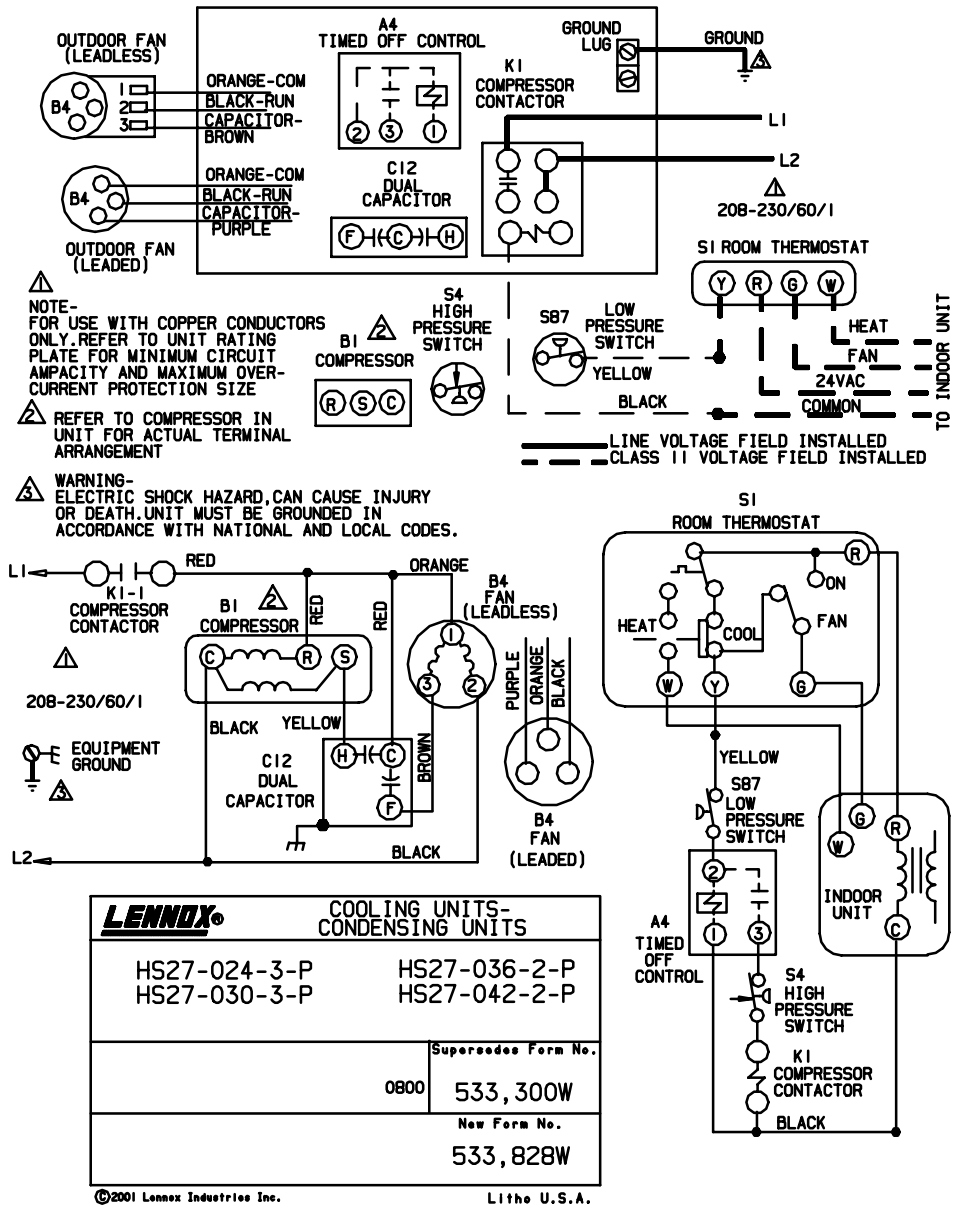

Operation Sequence

- 1 Cooling demand energizes thermostat terminal Y. Voltage from terminal Y passes through low pressure switch and the timed off control (TOC), which energizes K1 compressor contactor coil (provided 5 minute delay is satisfied).
- 2 K1-1 and K1-2 contacts close, energizing compressor B1 and outdoor fan B4.
- 3 When cooling demand is satisfied, K1-1 and K1-2 open, compressor and outdoor fan are de-energized. Time off control begins 5 minute off time.

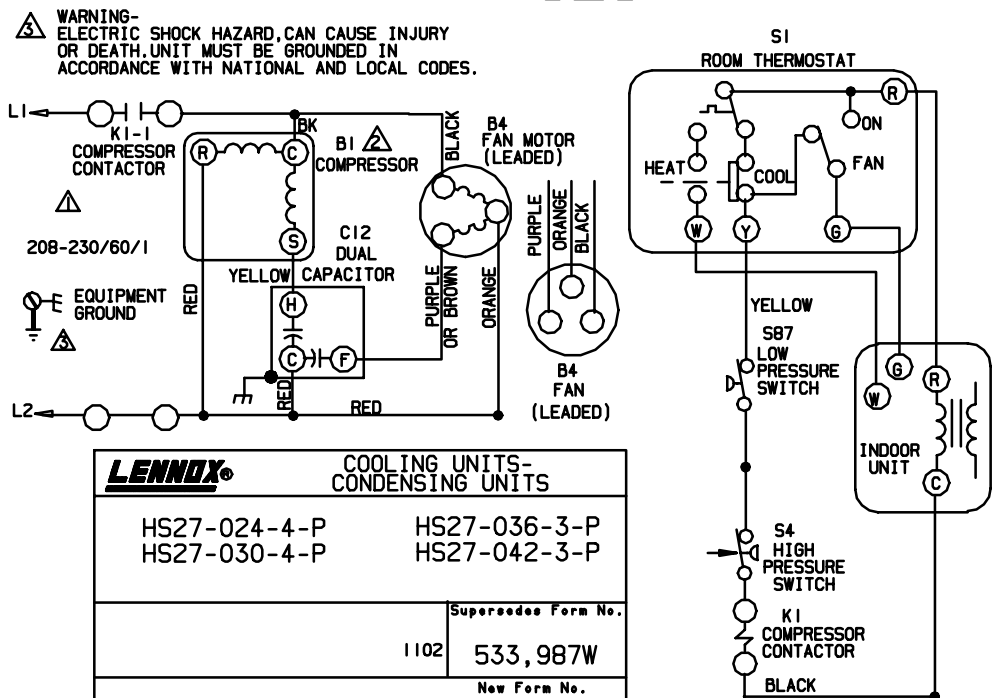
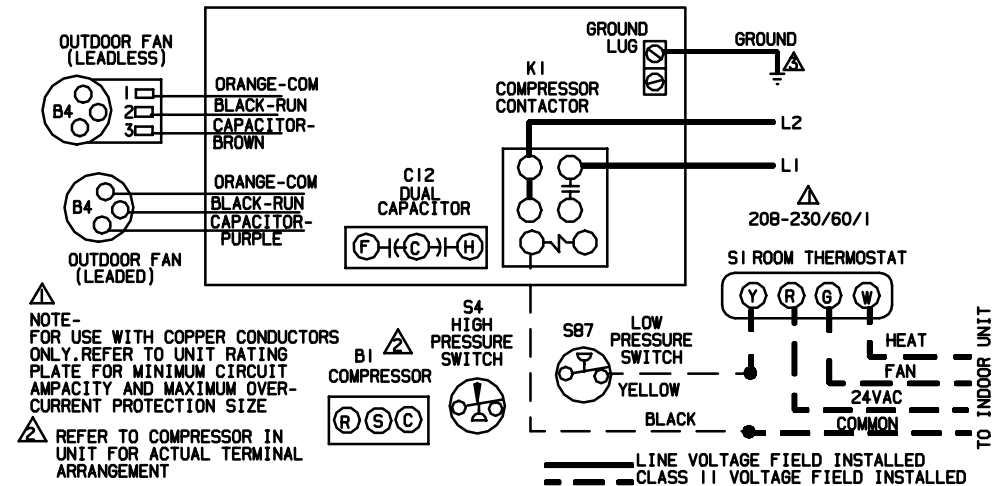

LENNOX®		COOLING UNITS- CONDENSING UNITS	
HS27-024-4-P	HS27-036-3-P		
HS27-030-4-P	HS27-042-3-P		
		Supersedes Form No.	
		1102	533,987W
		New Form No.	
		534,235W	

©2002 Lennox Industries Inc. Litho U.S.A.

Operation Sequence

- 1 Cooling demand energizes thermostat terminal Y. Voltage from terminal Y passes through low pressure switch and energizes K1 compressor contactor coil.
- 2 K1-1 and K1-2 contacts close, energizing compressor B1 and outdoor fan B4.
- 3 When cooling demand is satisfied, K1-1 and K1-2 open, compressor and outdoor fan are de-energized.