

**G50UHi Series Units**

G50UHi series units are mid-efficiency gas furnaces used for upflow or horizontal applications only, manufactured with Lennox Duralok Plus® heat exchangers formed of aluminized steel. G50UHi units are available in heating capacities of 66,000 to 154,000 Btuh and cooling applications up to 5 tons. Refer to Engineering Handbook for proper sizing.

Units are factory equipped for use with natural gas. Kits are available for conversion to LPG operation. G50UHi model units are equipped with the Lennox SureLight® silicon nitride ignition system and blower control module. The blower control module allows the G50UHi to maintain a constant CFM over a wide range of operating static pressure. All units use a redundant gas valve to assure safety shut-off as required by C.S.A.

All specifications in this manual are subject to change. Procedures outlined in this manual are presented as a recommendation only and do not supersede or replace local or state codes. In the absence of local or state codes, the guidelines and procedures outlined in this manual (except where noted) are recommended only and do not constitute code.

**TABLE OF CONTENTS**

Introduction .....	1
Specifications .....	2
High Altitude .....	3
Blower Data .....	4
Parts Identification .....	6
I Unit Components .....	8
II Installation .....	17
III Start Up .....	17
IV Heating System Service Checks .....	17
V Typical Operating Characteristics .....	20
VI Maintenance .....	20
VII Wiring and Sequence of Operation .....	22
VIII Troubleshooting .....	28



**⚠ IMPORTANT**

**Improper installation, adjustment, alteration, service or maintenance can cause property damage, personal injury or loss of life. Installation and service must be performed by a qualified installer, service agency or the gas supplier.**

**⚠ WARNING**



**Electric shock hazard. Can cause injury or death. Before attempting to perform any service or maintenance, turn the electrical power to unit OFF at disconnect switch(es). Unit may have multiple power supplies.**

**⚠ WARNING**

**Sharp edges. Be careful when servicing unit to avoid sharp edges which may result in personal injury.**

## SPECIFICATIONS

Gas Heating Performance		Model No.	G50UHi-36A-070	G50UHi-36B-090	G50UHi-48B-090	
Input - Btuh (kW)			66,000 (19.3)	88,000 (25.8)	88,000 (25.8)	
Output - Btuh (kW)			54,100 (15.8)	72,100 (21.1)	72,100 (21.1)	
1 AFUE			80.0%	80.0%	80.0%	
California Seasonal Efficiency			74.8%	75.7%	75.3%	
High static (CSA) - in. w.g. (Pa)			.50 (124)	.50 (124)	.50 (124)	
Temperature rise range - °F (°C)			40 - 70 (22 - 39)	40 - 70 (22 - 39)	40 - 70 (22 - 39)	
Connections						
Flue - in. (mm) round			4 (102)	4 (102)	4 (102)	
Gas pipe size IPS - in. (mm)			1/2 (12.7)	1/2 (12.7)	1/2 (12.7)	
Indoor Blower						
Wheel nominal diameter x width - in. (mm)			10 x 8 (254 x 203)	10 x 8 (254 x 203)	10 x 10 (254 x 254)	
Motor output - hp (W)			1/3 (249)	1/3 (249)	1/2 (373)	
Tons (kW) of add-on cooling			2 - 3 (7.0 - 10.6)	2 - 3 (7.0 - 10.6)	2 - 4 (7.0 - 14.1)	
Shipping weight - 1 package			132 lbs. (60 kg)	146 lbs. (66 kg)	153 lbs (69 kg)	
Electrical characteristics		120 volts - 60 hertz - 1 phase (less than 12 amps)				
OPTIONAL ACCESSORIES - MUST BE ORDERED EXTRA						
Filters and Filter Racks		2 Air Filter and Rack Kit No. & size of filters	Horizontal (end) Side Return - in. (mm)	87L95 - (1) 14 x 25 x 1 in. (356 x 635 x 25 mm) Single 44J22/Ten Pack 66K63 (1) 16 x 25 x 1(406 x 635 x 25)	87L96 - (1) 18 x 25 x 1 in. (457 x 635 x 25 mm) Single 44J22/ Ten Pack 66K63 (1) 16 x 25 x 1(406 x 635 x 25)	87L96 - (1) 18 x 25 x 1 in. (457 x 635 x 25 mm) Single 44J22/ Ten Pack 66K63 (1) 16 x 25 x 1(406 x 635 x 25)
EZ Filter Base		Catalog Number - Ship. Wt.		73P55 - 6 lbs. (3 kg)	73P56 - 7 lbs. (3 kg)	73P56 - 7 lbs. (3 kg)
		Dimensions - H x W x D		4 x 14-1/4 x 28-5/8 in. (102 x 362 x 727 mm)	4 x 17-5/8 x 28-5/8 in. (102 x 448 x 727 mm)	4 x 17-5/8 x 28-5/8 in. (102 x 448 x 727 mm)
		Number and size of filter (field provided) - in. (mm)		14 x 25 x 1 (356 x 635 x 25)	16 x 25 x 1 (406 x 635 x 25)	16 x 25 x 1 (406 x 635 x 25)
Gas Accessories		3 High Altitude Orifice Kit - Nat. Gas Only		47M82	47M82	47M82
		4 High Altitude Pressure Switch Kit		56L32	49L90	49L90
		4501-7500 ft. (1372-2286 m)				
		7501-10,000 ft. (2286-3048 m)		56L32	15M22	15M22
		LPG/Propane Kit 0-7500 ft. (0-2286 m)		45L60	45L60	45L60
		7501-10,000 ft. (2286-3048 m)		47M81	47M81	47M81
Horizontal Support Frame Kit - Shipping Weight				56J18 - 18 lbs. (8 kg)	56J18 - 18 lbs. (8 kg)	56J18 - 18 lbs. (8 kg)
Relay Kit				56L68	56L68	56L68
SignatureStat™ - Home Comfort Controller				51M26	51M26	51M26
Vent Adaptor - 6 in. 152 (mm) connection size				18M79 - 2 lbs. (1 kg)	18M79 - 2 lbs. (1 kg)	18M79 - 2 lbs. (1 kg)

NOTE - Filters and provisions for mounting are not furnished and must be field provided.

<sup>1</sup> Annual Fuel Utilization Efficiency based on DOE test procedures and according to FTC labeling regulations. Isolated combustion system rating for non-weatherized furnaces.

<sup>2</sup> Cleanable polyurethane frame type filter.

<sup>3</sup> Required for proper operation at altitudes from 7501 to 10,000 ft. (2286 to 3048 m).

<sup>4</sup> Required for proper operation at altitudes over 4500 ft. (1370 m).

## SPECIFICATIONS

Gas Heating Performance	Model No.	G50UHi-60C-110	G50UHi-60D-135
	Input - Btuh (kW)	110,000 (32.2)	132,000 (38.7)
	Output - Btuh (kW)	89,400 (26.2)	106,900 (31.3)
	<sup>1</sup> AFUE	80.0%	80.0%
	California Seasonal Efficiency	73.9%	75.0%
	High static (CSA) - in. w.g. (Pa)	.50 (124)	.50 (124)
	Temperature rise range - °F (°C)	30 - 60 (18 - 36)	45 - 75 (25 - 42)
Connections	Flue - in. (mm) round	4 (102)	<sup>5</sup> 4 (102)
	Gas pipe size IPS - in. (mm)	1/2 (12.7)	1/2 (12.7)
Indoor Blower	Wheel nominal diameter x width - in. (mm)	11-1/2 x 10 (292 x 254)	11-1/2 x 10 (292 x 254)
	Motor output - hp (W)	1 (746)	1 (746)
	Tons (kW) of add-on cooling	5 (17.6)	5 (17.6)
Shipping weight - 1 package		175 lbs. (79 kg)	195 lbs. (88 kg)
Electrical characteristics		120 volts - 60 hertz - 1 phase (less than 12 amps)	

## OPTIONAL ACCESSORIES - MUST BE ORDERED EXTRA

Filters and Filter Bases	<sup>2</sup> Air Filter and Rack Kit	Horizontal (end) - in. (mm)	<b>87L97</b> (1) 20 x 25 x 1 (508 x 635 x 25)	<b>87L98</b> (1) 25 x 25 x 1 (635 x 635 x 25)
	Number & size of filters	Side Return - in. (mm)	Single <b>44J22</b> or Ten Pack <b>66K63</b> (1) 16 x 25 x 1 (406 x 635 x 25)	Single <b>44J22</b> or Ten Pack <b>66K63</b> (1) 16 x 25 x 1 (406 x 635 x 25)
EZ Filter Base	Catalog Number - Shipping Weight		<b>73P57</b> - 8 lbs. (4 kg)	<b>73P58</b> - 10 lbs. (5 kg)
	Dimensions - H x W x D - in. (mm)		4 x 21-5/8 x 28-5/8 (102 x 549 x 727)	4 x 24-5/8 x 28-5/8 (102 x 625 x 727)
	Number and size of filter (field provided)		20 x 25 x 1 in. (508 x 635 x 25 mm)	24 x 24 x 1 in. (610 x 610 x 25 mm)
Gas Accessories	<sup>3</sup> High Altitude Orifice Kit - Nat. Gas Only		<b>47M82</b>	<b>47M82</b>
	<sup>4</sup> High Altitude Pressure Switch Kit	4501-7500 ft. (1372-2286 m)	<b>49L90</b>	<b>49L90</b>
		7501-10,000 ft. (2286-3048 m)	<b>15M22</b>	<b>15M22</b>
	LPG/Propane Kit	0-7500 ft. (0-2286 m)	<b>45L60</b>	<b>45L60</b>
7501-10,000 ft. (2286-3048 m)		<b>47M81</b>	<b>47M81</b>	
Horizontal Support Frame Kit - Shipping Weight			<b>56J18</b> - 18 lbs. (8 kg)	<b>56J18</b> - 18 lbs. (8 kg)
Relay Kit			<b>56L68</b>	<b>56L68</b>
SignatureStat™ - Home Comfort Controller			<b>51M26</b>	<b>51M26</b>
Vent Adaptor - 6 in. 152 (mm) connection size			<b>18M79</b> - 2 lbs. (1 kg)	<b>18M79</b> - 2 lbs. (1 kg)

NOTE - Filters and provisions for mounting are not furnished and must be field provided.

<sup>1</sup> Annual Fuel Utilization Efficiency based on DOE test procedures and according to FTC labeling regulations. Isolated combustion system rating for non-weatherized furnaces.

<sup>2</sup> Cleanable polyurethane frame type filter.

<sup>3</sup> Required for proper operation at altitudes from 7501 to 10,000 ft. (2286 to 3048 m).

<sup>4</sup> Required for proper operation at altitudes over 4500 ft. (1370 m).

<sup>5</sup> Flue connection on the unit is 4 in. (102 mm) diameter. Most applications will require 5 in. (127 mm) venting and field supplied 4 x 5 in. (102 x 127 mm) adaptor. See Venting Tables in the Installation Instructions for detailed information.

## HIGH ALTITUDE INFORMATION

All models - Pressure regulator adjustment may be required depending on altitude. See below for proper pressure regulator setting.

### Manifold Pressure (Outlet) in. w.g. (kPa)

FUEL	ALTITUDE ft. (m)			
	0-4500 (0-1372)	4501-5500 (1373-1676)	5501-6500 (1677-1981)	6501-7500 (1982-2286)
Natural Gas	3.5 (.87)	3.3 (.82)	3.2 (.80)	3.1 (.77)
LPG/Propane	10.0 (2.49)	10.0 (2.49)	10.0 (2.49)	10.0 (2.49)

Pressure switch is factory set. No adjustment is necessary.

All models use the factory installed pressure switch from 0-4500 feet (0-1370 m).





All models require a High Altitude Pressure Switch Kit if installed at altitudes above 4500 feet (1372 m).

All natural gas models require a High Altitude Orifice Kit at altitudes of 7500-10,000 feet (2286-3048 m).

See Specifications table for ordering information.

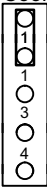
## BLOWER DATA

### JUMPER SELECTION FOR BLOWER CONTROL MODULE

Blower Mode	Available Speed Selector Settings		Factory Default		Cool	Heat	Fan	Dehum	Ramp
	36A-070 36B-090	48B-090 60C-110 60D-135	36A-070 36B-090	48B-090 60C-110 60D-135					
Cool	1, 1, 3, 4	1, 1, 3, 4	1	1					
Heat	1, 2, 3, 4	2, 3, 4, 5	3	4					
Fan	2, 5, 6, 7	2, 5, 6, 7	7	7					
Dehumid	3, 4, 5, 6	3, 4, 5, 6	3	3					
Ramp	Off, A, B, C	Off, A, B, C	A	A					

Jumper is placed across the two pins to select the noted speed or ramping profile.  
NOTE - Jumper selections are NOT printed on the Blower Control Module.

#### G50UHi-36A-070

External Static Pressure		Jumper Speed Selector																							
		Speed 1 Factory Default Cool			Speed 2			Speed 3 Factory Default Heat/Dehumid			Speed 4			Speed 5			Speed 6			Speed 7 Factory Default Fan					
in. w.g.	Pa	cfm	L/s	Watts	cfm	L/s	Watts	cfm	L/s	Watts	cfm	L/s	Watts	cfm	L/s	Watts	cfm	L/s	Watts	cfm	L/s	Watts	cfm	L/s	Watts
0	0	1290	610	450	1190	565	380	1085	510	330	955	450	260	855	405	210	775	365	185	650	305	135			
0.1	25	1295	610	480	1190	560	405	1095	515	345	970	460	290	845	400	225	775	365	190	655	310	145			
0.2	50	1300	615	510	1190	560	425	1095	515	370	975	460	305	845	400	240	770	360	205	640	300	150			
0.3	75	1285	605	510	1190	560	450	1095	515	385	975	460	320	855	405	260	765	360	220	610	290	160			
0.4	100	1220	575	500	1190	560	465	1090	515	405	970	455	335	845	400	275	760	360	235	590	275	175			
0.5	125	1210	570	520	1175	555	465	1090	515	420	960	455	350	835	395	285	735	350	245	580	275	185			
0.6	150	1165	550	525	1150	540	470	1065	505	450	950	450	375	815	385	305	720	340	260	565	265	200			
0.7	175	1125	530	500	1105	520	490	1040	490	430	945	445	380	800	380	325	705	335	280	550	260	210			
0.8	200	1065	500	480	1060	500	475	985	465	445	875	415	390	790	375	330	690	325	290	525	250	225			
0.9	225	935	440	435	930	440	435	885	420	410	825	390	390	740	350	350	675	320	295	510	240	235			

NOTES - All air data is measured external to unit with 1 in. (25 mm) cleanable filter (not furnished - field provided) in place. Also see Filter Air Resistance table.  
Air volume based on bottom return air. Actual air volume may vary on side return air applications.

#### G50UHi-36B-090

External Static Pressure		Jumper Speed Selector																							
		Speed 1 Factory Default Cool			Speed 2			Speed 3 Factory Default Heat/Dehumid			Speed 4			Speed 5			Speed 6			Speed 7 Factory Default Fan					
in. w.g.	Pa	cfm	L/s	Watts	cfm	L/s	Watts	cfm	L/s	Watts	cfm	L/s	Watts	cfm	L/s	Watts	cfm	L/s	Watts	cfm	L/s	Watts	cfm	L/s	Watts
0	0	1275	600	410	1165	550	335	1045	495	290	940	445	250	860	405	215	780	370	185	665	315	140			
0.1	25	1280	605	425	1185	560	365	1075	505	310	965	455	260	850	400	220	780	370	185	670	315	145			
0.2	50	1300	615	450	1205	570	390	1090	515	330	970	460	285	865	410	235	785	370	200	665	315	155			
0.3	75	1295	610	465	1210	570	410	1095	515	350	980	460	300	865	410	250	780	365	215	645	305	160			
0.4	100	1295	610	490	1215	570	435	1100	520	375	985	465	315	865	410	265	775	365	225	625	295	180			
0.5	125	1290	610	500	1210	570	455	1095	520	390	985	465	335	860	405	280	770	360	245	610	290	190			
0.6	150	1275	605	520	1205	570	470	1090	515	410	975	460	355	855	405	300	760	360	255	595	280	205			
0.7	175	1200	565	510	1195	565	475	1090	515	435	965	455	375	840	395	310	745	350	270	580	275	215			
0.8	200	1175	555	530	1155	545	500	1065	505	425	965	455	415	830	390	340	730	345	295	560	265	225			
0.9	225	1115	525	505	1125	530	500	1030	485	445	920	435	395	790	375	330	715	335	320	550	260	240			

NOTES - All air data is measured external to unit with 1 in. (25 mm) cleanable filter (not furnished - field provided) in place. Also see Filter Air Resistance table.  
Air volume based on bottom return air. Actual air volume may vary on side return air applications.

**G50UHi-48B-090**

External Static Pressure	Jumper Speed Selector																					
	Speed 1 Factory Default Cool			Speed 2			Speed 3 Factory Default Dehumid			Speed 4 Factory Default Heat			Speed 5			Speed 6			Speed 7 Factory Default Fan			
	in. w.g.	Pa	cfm	L/s	Watts	cfm	L/s	Watts	cfm	L/s	Watts	cfm	L/s	Watts	cfm	L/s	Watts	cfm	L/s	Watts		
0	0	1800	850	655	1585	750	495	1465	690	420	1345	635	360	1225	575	300	1060	500	230	890	420	170
0.1	25	1795	845	670	1590	750	515	1485	700	455	1365	645	395	1225	580	320	1050	495	235	845	400	175
0.2	50	1755	830	690	1580	745	545	1495	705	490	1375	650	415	1240	585	350	1030	485	255	820	385	185
0.3	75	1710	805	690	1565	740	565	1470	695	500	1370	645	445	1245	585	375	1025	485	285	760	360	190
0.4	100	1605	755	660	1550	730	585	1450	685	525	1355	640	455	1225	580	395	1015	480	300	745	350	210
0.5	125	1610	760	715	1510	715	580	1435	675	540	1340	630	485	1210	570	415	1005	475	330	740	350	225
0.6	150	1550	730	680	1475	695	600	1410	665	570	1325	625	510	1190	560	445	980	465	345	745	350	250
0.7	175	1470	695	640	1430	675	625	1365	645	555	1290	610	500	1170	550	455	965	455	355	715	340	265
0.8	200	1350	635	585	1370	645	615	1315	620	590	1225	575	535	1130	530	470	955	450	370	695	325	285
0.9	225	1220	575	550	1260	595	575	1260	595	575	1195	565	540	1090	515	490	935	440	400	670	315	295

NOTES - All air data is measured external to unit with 1 in. (25 mm) cleanable filter (not furnished - field provided) in place. Also see Filter Air Resistance table.  
Air volume based on bottom return air. Actual air volume may vary on side return air applications.

**G50UHi-60C-110**

External Static Pressure	Jumper Speed Selector																					
	Speed 1 Factory Default Cool			Speed 2			Speed 3 Factory Default Dehumid			Speed 4 Factory Default Heat			Speed 5			Speed 6			Speed 7 Factory Default Fan			
	in. w.g.	Pa	cfm	L/s	Watts	cfm	L/s	Watts	cfm	L/s	Watts	cfm	L/s	Watts	cfm	L/s	Watts	cfm	L/s	Watts	cfm	L/s
0	0	2150	1015	915	1965	925	735	1850	875	640	1695	800	535	1515	715	425	1295	610	315	1000	470	215
0.1	25	2140	1010	935	1960	925	775	1830	865	660	1695	800	565	1535	725	460	1345	635	355	975	460	220
0.2	50	2085	985	930	1960	925	815	1825	860	710	1700	800	595	1545	730	500	1375	650	400	1000	475	240
0.3	75	2085	985	1000	1965	925	855	1825	860	735	1675	790	610	1540	725	520	1375	650	420	1075	505	290
0.4	100	2055	970	1015	1945	920	890	1825	860	775	1680	790	645	1525	720	545	1375	650	455	1075	505	310
0.5	125	2010	950	1025	1895	895	890	1810	855	810	1680	795	690	1515	715	580	1350	635	465	1075	505	335
0.6	150	1950	920	1015	1885	890	965	1795	845	850	1640	775	705	1505	710	605	1335	630	490	1050	495	345
0.7	175	1900	895	1010	1850	875	970	1760	830	865	1630	770	735	1485	700	625	1335	630	530	1010	480	360
0.8	200	1845	870	1025	1790	845	950	1700	800	875	1605	755	755	1460	690	645	1315	620	545	1000	470	385
0.9	225	1740	820	980	1715	810	955	1665	785	915	1570	740	785	1425	670	675	1275	600	570	995	470	420

NOTES - All air data is measured external to unit with 1 in. (25 mm) cleanable filter (not furnished - field provided) in place. Also see Filter Air Resistance table.  
Air volume based on side return air. Actual air volume may vary on bottom return air applications.

**G50UHi-60D-135**

External Static Pressure	Jumper Speed Selector																					
	Speed 1 Factory Default Cool			Speed 2			Speed 3 Factory Default Dehumid			Speed 4 Factory Default Heat			Speed 5			Speed 6			Speed 7 Factory Default Fan			
	in. w.g.	Pa	cfm	L/s	Watts	cfm	L/s	Watts	cfm	L/s	Watts	cfm	L/s	Watts	cfm	L/s	Watts	cfm	L/s	Watts	cfm	L/s
0	0	2160	1020	905	1985	935	735	1910	900	665	1705	805	520	1580	745	460	1290	610	315	1040	490	230
0.1	25	2165	1020	945	1975	930	770	1895	895	695	1725	815	565	1595	750	475	1345	635	350	990	465	220
0.2	50	2115	995	935	1970	930	805	1890	890	730	1710	805	575	1605	755	525	1380	650	385	945	445	225
0.3	75	2055	970	925	1975	935	845	1895	895	770	1705	805	620	1600	755	545	1395	660	425	1010	475	260
0.4	100	2090	985	1015	1960	925	870	1885	890	805	1705	805	650	1590	750	565	1410	665	455	1115	525	330
0.5	125	2065	975	1040	1940	915	895	1865	880	825	1700	800	670	1585	750	590	1380	650	465	1120	530	350
0.6	150	2020	955	1030	1880	885	880	1855	875	865	1685	795	700	1570	740	620	1355	640	490	1105	520	370
0.7	175	1965	925	1040	1880	885	965	1815	855	880	1650	780	725	1550	730	650	1340	630	510	1065	500	375
0.8	200	1910	900	1040	1850	875	960	1760	830	880	1645	775	760	1535	725	670	1340	635	550	1055	500	395
0.9	225	1805	850	975	1785	845	985	1740	820	920	1610	760	785	1500	710	695	1310	620	555	1035	490	430

NOTES - All air data is measured external to unit with 1 in. (25 mm) cleanable filter (not furnished - field provided) in place. Also see Filter Air Resistance table.  
Air volume based on side return air. Actual air volume may vary on bottom return air applications.

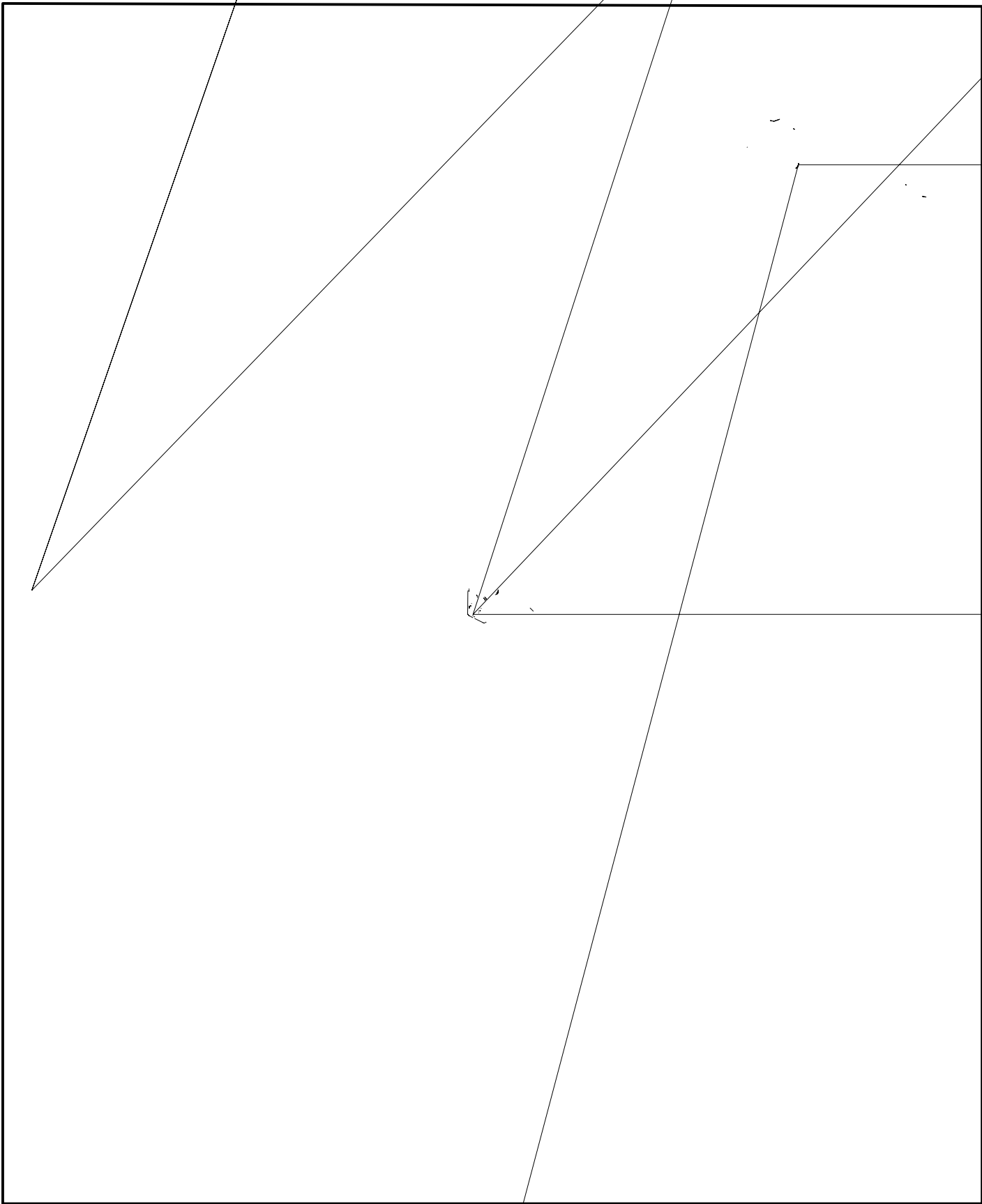

**FIGURE 1**

**G50UHi PARTS IDENTIFICATION  
(HORIZONTAL POSITION)**

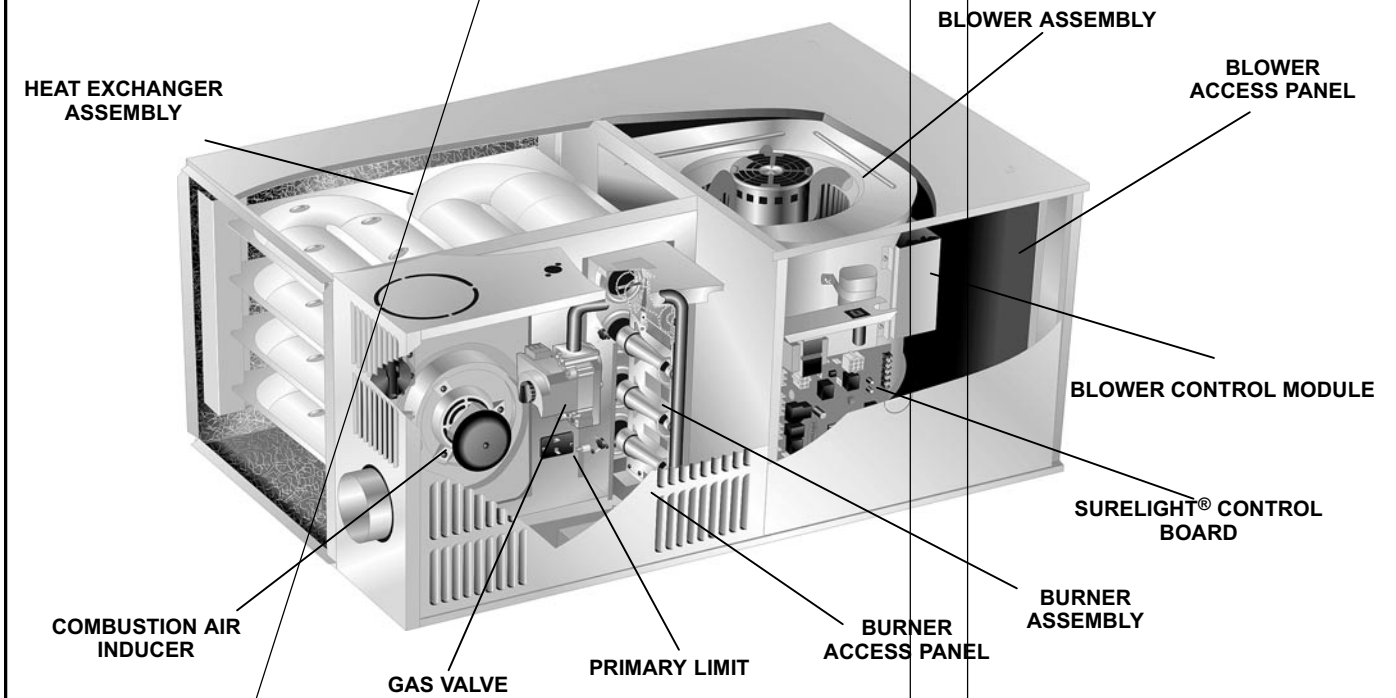

**FIGURE 2**

**G50UHi HEATING COMPONENTS**

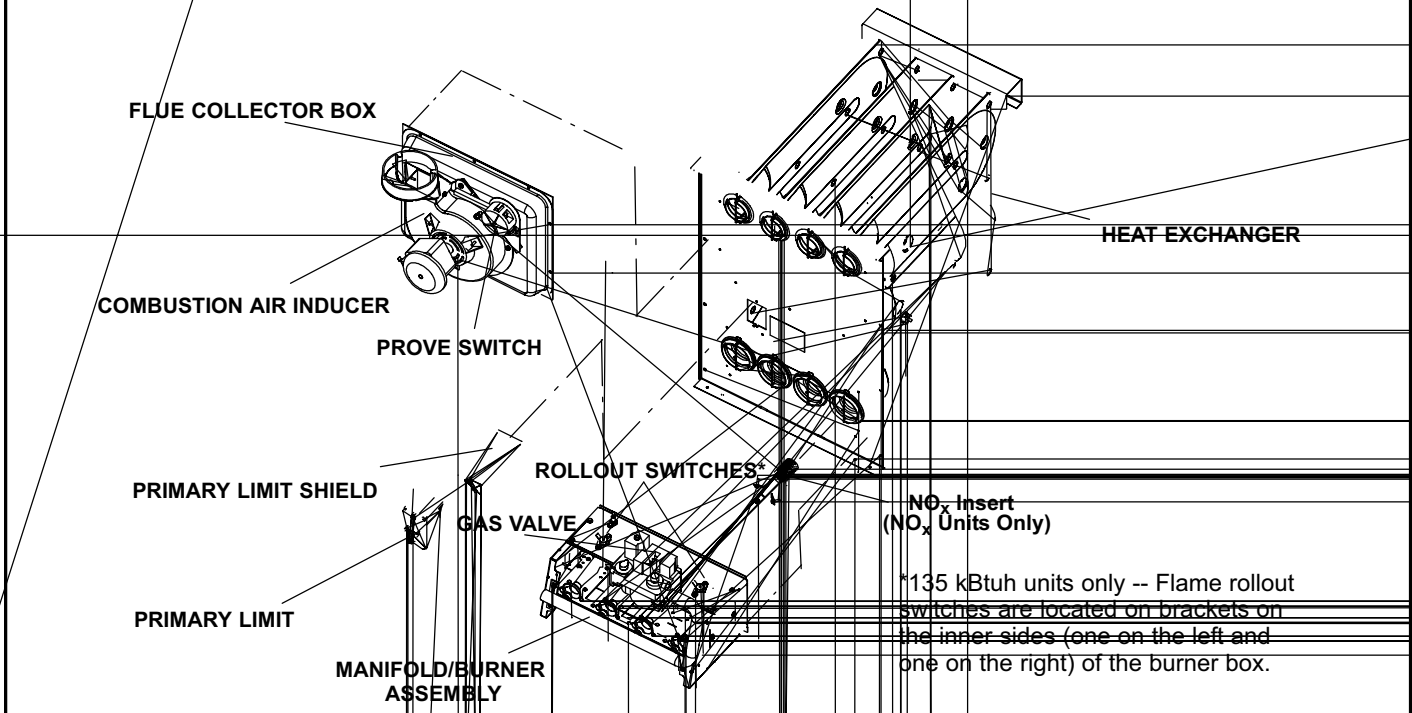

**FIGURE 3**

## I-UNIT COMPONENTS

G50UHi unit components are shown in figures 1, 2 and 3. The gas valve, combustion air inducer and burners can be accessed by removing the burner access panel. Electrical components are in the control box (figure 4) found in the blower section.

G50UHi units are factory equipped with a bottom return air panel in place. The panel is designed to be field removed as required for bottom air return. Markings are provided for side return air and may be cut out in the field.

### ELECTROSTATIC DISCHARGE (ESD)

#### Precautions and Procedures

## ⚠ CAUTION

Electrostatic discharge can affect electronic components. Take precautions during furnace installation and service to protect the furnace's electronic controls. Precautions will help to avoid control exposure to electrostatic discharge by putting the furnace, the control and the technician at the same electrostatic potential. Neutralize electrostatic charge by touching hand and all tools on an unpainted unit surface, such as the gas valve or blower deck, before performing any service procedure.

### 1. Control Transformer (T1)

A transformer located in the control box provides power to the low voltage section of the unit. Transformers on all models are rated 40VA with a 120V primary and a 24V secondary.

### 2. Door Interlock Switch (S51)

A door interlock switch rated 14A at 125VAC is wired in series with line voltage. When the blower door is removed the unit will shut down.

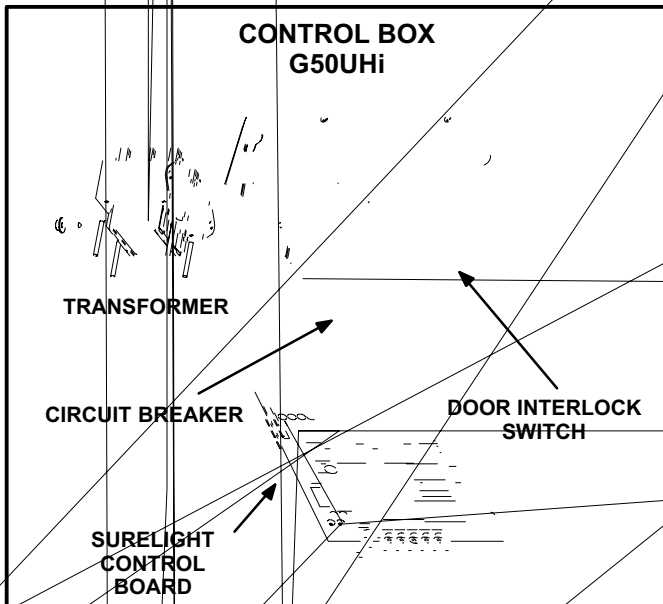

FIGURE 4



**b-Fan Time Control**

The fan on time of 45 seconds is not adjustable. Fan off time (time that the blower operates after the heat demand has been satisfied) can be adjusted by flipping the dip switches located on the SureLight integrated control. The unit is shipped with a factory fan off setting of 90 seconds. Fan off time will affect comfort and is adjustable to satisfy individual applications. For customized comfort, monitor the supply air temperature once the heat demand is satisfied. Note the supply air temperature at the instant the blower is de-energized. Adjust the fan-off delay to achieve

a supply air temperature between 90° - 110° at the instant the blower is de-energized. (Longer delay times allow for lower air temperature, shorter delay times allow for higher air temperature). See figure 7.

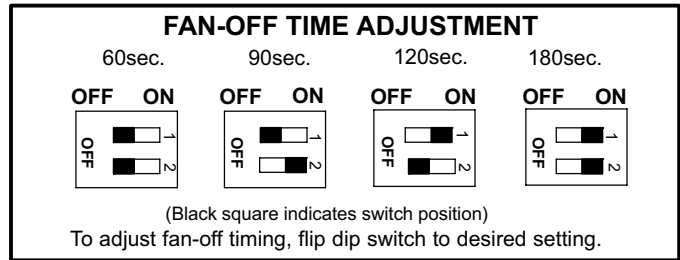

**FIGURE 7**

The SureLight board is equipped with two LED lights for troubleshooting. The diagnostic codes are listed below in table 4.

**TABLE 4**

**DIAGNOSTIC CODES**

Make sure to Identify LED'S Correctly..

LED #1 97L48 - DIAG 1 Green 69M15 - DS1 Red	LED #2 97L48 - DIAG2 Green 69M15 - DS2 Green	DESCRIPTION
SIMULTANEOUS SLOW FLASH	SIMULTANEOUS SLOW FLASH	Power on - Normal operation. Also signaled during cooling and continuous fan.
SIMULTANEOUS FAST FLASH	SIMULTANEOUS FAST FLASH	Normal operation - signaled when heating demand initiated at thermostat.
SLOW FLASH	ON	Primary or secondary limit switch open. Limit must close within 3 minutes or unit goes into 1 hour Watchgurad.
OFF	SLOW FLASH	Prove switch open OR: Blocked inlet/exhaust vent; OR: Prove switch closed prior to activation of combustion air inducer.
ALTERNATING SLOW FLASH	ALTERNATING SLOW FLASH	Watchguard -- burners failed to ignite.
SLOW FLASH	OFF	Flame sensed without gas valve energized.
ON	SLOW FLASH	Rollout switch open. OR: Low voltage pin connector improperly attached.
ON ON OFF	ON OFF ON	Circuit board failure or control wired incorrectly.
FAST FLASH	SLOW FLASH	Main power polarity reversed. Switch line and neutral.
SLOW FLASH	FAST FLASH	Low flame signal. See table 17 for flame signal Replace flame sense rod.
ALTERNATING FAST FLASH	ALTERNATING FAST FLASH	The following conditions are sensed during the ignitor warm-up period only: 1) Improper main ground; 2) Broken ignitor; OR: Open ignitor circuit; 3) Line voltage below 75 volts. (If voltage lower than 75 volts prior to ignitor warm-up, control will signal waiting on call from thermostat, and will not respond.

NOTE - Slow flash rate equals 1 Hz (one flash per second). Fast flash rate equals 3 Hz (three flashes per second).

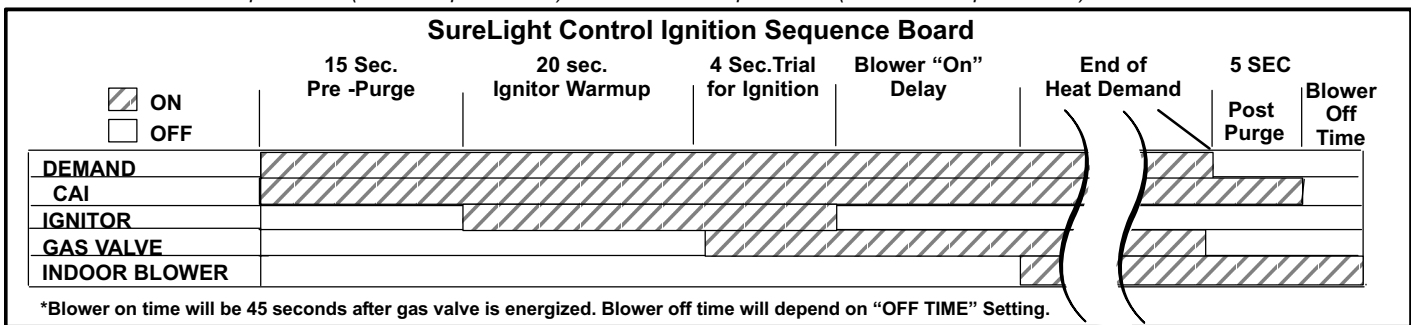

\*Blower on time will be 45 seconds after gas valve is energized. Blower off time will depend on "OFF TIME" Setting.

**FIGURE 8**

## 5. SureLight® Integrated Ignition Control 69M15 (A92)

The SureLight system consists of ignition control board (figure 9), ignitor (figure 11) and sensor (figure 12). The ignition control and ignitor work in combination to ensure furnace ignition and ignitor durability. The ignition control, controls all major furnace operations. The ignition control also features two LED lights (DS1 red and DS2 green) for troubleshooting and two 120 volt accessory terminals each rated at (1) one amp. A 24 volt accessory terminal rated at 0.5 amps is also provided. Table 5 shows 24 volt and 120 volt control terminal designations. Tables 6 and 7 show jack plug terminal designations. See table 4 for troubleshooting diagnostic codes. Units equipped with the SureLight system can be used with either electronic or electro-mechanical thermostats without modification. Each time power is applied to the furnace, the ignition control performs a selfcheck. The SureLight ignitor is made of durable silicon-nitride. Ignitor longevity is also enhanced by voltage ramping by the control board. The ignition control finds the lowest ignitor temperature which will successfully light the burner, thus increasing the life of the ignitor.

**TABLE 5**

IGNITION CONTROL 69M15 TERMINAL DESIGNATIONS	
COOL	Blower - Cooling Speed (120V)
HEAT	Blower - Heating (120V)
PARK	Unused blower lead not energized
FAN	Continuous Low Blower Speed
EAC	Accessory Terminal (120V)
XFMR	Transformer (120V)
LINE	Input (120V)
HUM	Heat Only Accessory (120V)
5 Terminals	120 Volt Neutral
FS	Flame Sensor
24V HUM	Heat Only Accessory (24V)

**TABLE 6**

IGNITION CONTROL 69M15 TERMINAL DESIGNATIONS	
PIN #	FUNCTION
1	Combustion Air Inducer Line Voltage
2	Ignitor Voltage
3	Combustion Air Inducer Neutral
4	Ignitor Neutral

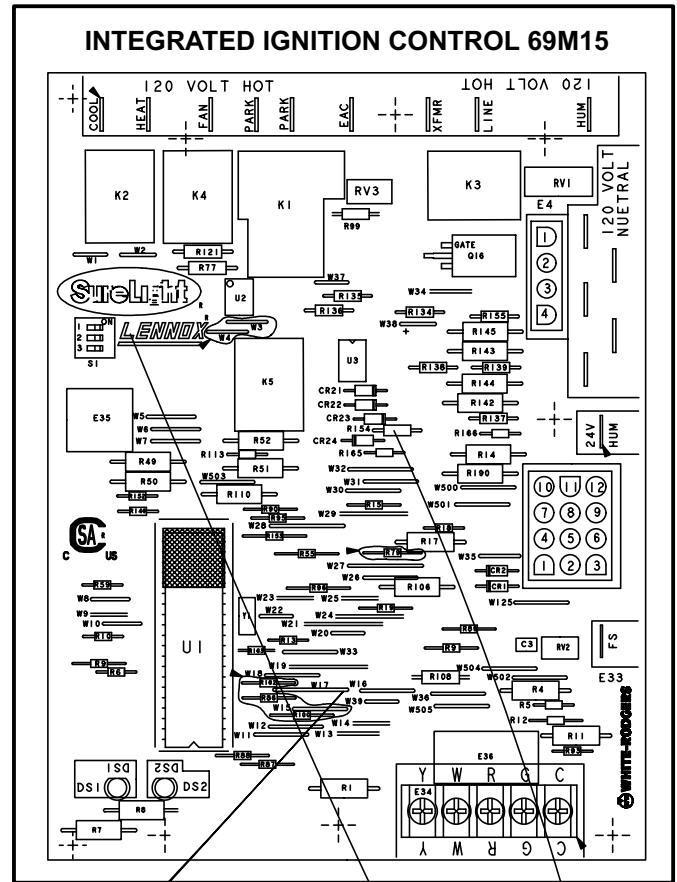

**FIGURE 9**

**c-Electronic Ignition (See Figure 8)**

On a call for heat the SureLight control monitors the combustion air inducer prove switch. The control will not begin the heating cycle if the prove switch is closed (by-passed). Once the proving switch is determined to be open, the combustion air inducer is energized. When the differential in the prove switch is great enough, the prove switch closes and a 15-second pre-purge begins. If the prove switch is not proven within 2-1/2 minutes, the control goes into Watchguard-Pressure Switch mode for a 5-minute re-set period.

After the 15-second pre-purge period, the SureLight ignitor warms up for 20 seconds during which the gas valve opens at 19 seconds for a 4-second trial for ignition. The ignitor stays energized during the trial until flame is sensed. If ignition is not proved during the 4-second period, the control will try four more times with an inter purge and warm-up time between trials of 35 seconds. After a total of five trials for ignition (including the initial trial), the control goes into Watchguard-Flame Failure mode. After a 60-minute reset period, the control will begin the ignition sequence again.

The SureLight control board has an added feature that prolongs the life of the ignitor. After a successful ignition, the SureLight control utilizes less power to energize the ignitor on successive calls for heat. The control continues to ramp down the voltage to the ignitor until it finds the lowest amount of power that will provide a successful ignition. This amount of power is used for 255 cycles. On the 256th call for heat, the control will again ramp down until the lowest power is determined and the cycle begins again.

**d-Fan Time Control Heating**

The heating fan on time of 45 seconds is not adjustable. Fan off time (time that the blower operates after the heat demand has been satisfied) can be adjusted by setting the S1 dip switches located on the SureLight integrated control. The unit is shipped with a factory fan off setting of 90 seconds. Fan off time will affect comfort and is adjustable to satisfy individual applications. For customized comfort, monitor the supply air temperature once the heat demand is satisfied. Note the supply air temperature at the instant the blower is de-energized. Adjust the fan-off delay to achieve a supply air temperature between 90° - 110° at the instant the blower is de-energized. (Longer delay times allow for lower air temperature, shorter delay times allow for higher air temperature). See table 8 for switch settings and fan delay times..

**e-Fan Time Control Cooling**

The cooling fan on time is fixed at 2 seconds and cannot be adjusted. Fan off time (time that the blower operates after the cool demand has been satisfied) can be adjusted by setting the S1 dip switches (switch 3) located on the SureLight integrated control. See table 8 for switch settings and fan delay times.

**TABLE 8**

<b>S1 DIP SWITCH SETTINGS</b>		
Heat Off Delay		
Switch 1	Switch 2	SECONDS
OFF	OFF	60
OFF	ON	90
ON	OFF	120
ON	ON	180
Cool Off Delay		
Switch 3		SECONDS
OFF		2
ON		45

## Blower Control Module (Figure 10)

G50UHi units are equipped with a blower control module which offers a variety of indoor blower speeds for selection. The module is wired between the SureLight ignition control board and the indoor blower motor. The module alters the frequency and voltage of the power supply to the blower to control blower speed. The module provides consistent CFM over a wider range of operating static pressures.

The module also features a dehumidification option. This option requires the use of a thermostat which includes a humidity sensor, as well as a relay, which must both be ordered separately. When this optional feature is used, the blower control module shifts the indoor blower motor to a lower speed (determined by the selector jumper) when the indoor thermostat indicates a dehumidification requirement.

The module includes a ramping profile selector, which offers passive humidity control during cooling operation. This feature does not require the use of a specific thermostat or an additional relay. There are three available ramping profiles. When one of the ramping profiles is used, the indoor blower is initially engaged at a lower speed to provide additional humidity control. After the selected time period (7-1/2, 10, or 15 minutes), the blower motor shifts to the regularly selected cooling speed.

The module/bracket assembly is located on the blower scroll just below the SureLight control board. Blower speeds are adjusted by altering the position of blower speed selector jumpers.

### Blower Control Module Settings

## ⚠ DANGER

Disconnect power from unit and wait at least 30 seconds to allow capacitors to discharge before removing blower control module cover. Failure to wait may cause personal injury or death.

Remove the cover panel from the module to access the selector jumpers. There are five selector pins in each column. These pins, when jumpered, correspond with four selection options for each function. The speed (or ramp) selection is listed in the space between the two pins. There are eight blower speeds and four ramping options available for selection on the control module. Refer to table 9 and figure 10. The blower speed settings and the corresponding CFMs are given in the BLOWER DATA section.

The ramping options provide a means of controlling humidity during cooling operation without the use of a humidity sensor or additional relay.

#### Ramping Option A (Factory Selection)

- Motor runs at 82% for approximately 7-1/2 minutes.
- If demand has not been satisfied after 7-1/2 minutes, motor runs at 100% until demand is satisfied.
- Once demand is met, motor ramps down to off.

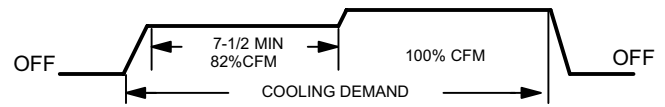

#### Ramping Option B

- Motor runs at 75% for approximately 10 minutes.
- If demand has not been satisfied after 10 minutes, motor runs at 100% until demand is satisfied.
- Once demand is met, motor ramps down to off.

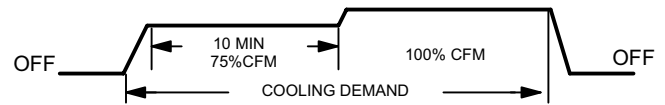

#### Ramping Option C

- Motor runs at 75% for approximately 15 minutes.
- If demand has not been satisfied after 15 minutes, the motor runs at 100% until demand is satisfied.
- Once demand is met, motor ramps down to off.

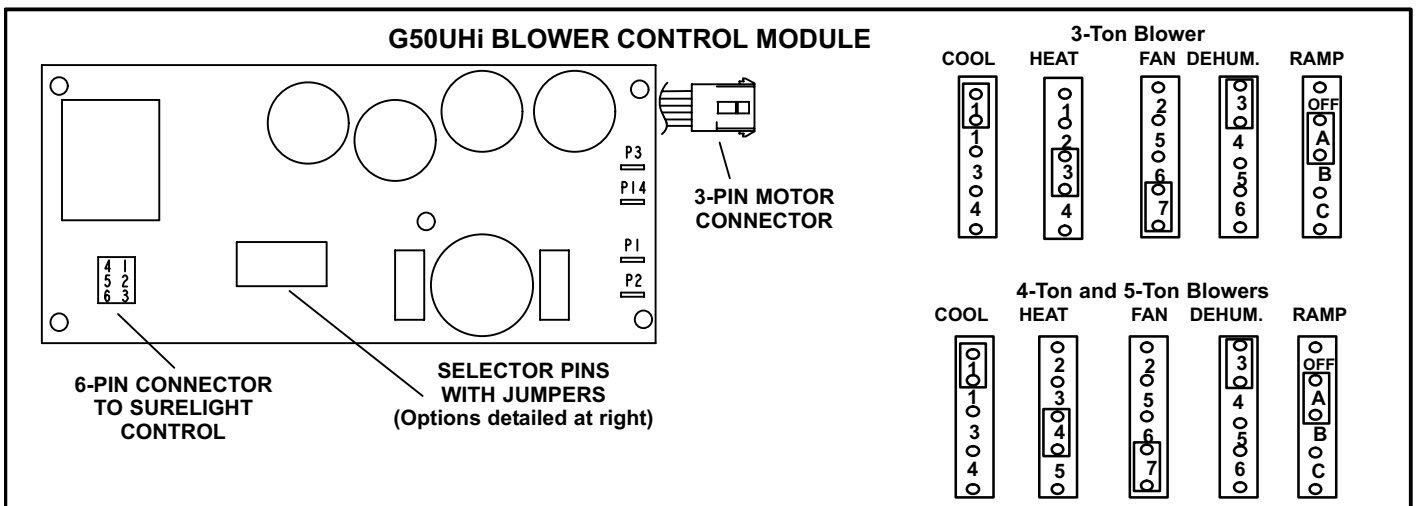
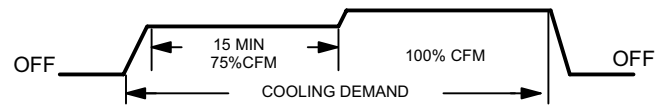

FIGURE

**TABLE 9**

<b>Blower Mode</b>	<b>Available Options</b>	<b>Factory Default</b>
Cool	Speeds 1, 3, 4	Speed 1
Heat (3-ton)	Speeds 1, 2, 3, 4	Speed 3
Heat (4 & 5-ton)	Speeds 2, 3, 4, 5	Speed 4
Fan	Speeds 2, 5, 6, 7	Speed 7
Dehumidification	Speeds 3, 4, 5, 6	Speed 3
Ramp	OFF, A, B, C	Ramp A

## 6. Ignitor

The SureLight<sup>®</sup> ignitor is made of durable silicon nitride. Ignitor longevity is enhanced by controlling voltage to the ignitor. The board finds the lowest ignitor temperature which will successfully light the burner, thus increasing the life of the ignitor. Due to this feature of the board, voltage cannot be measured so ignitor must be ohmed. Ohm value should be 10.9 to 19.7. See figure 11 for ignitor location.

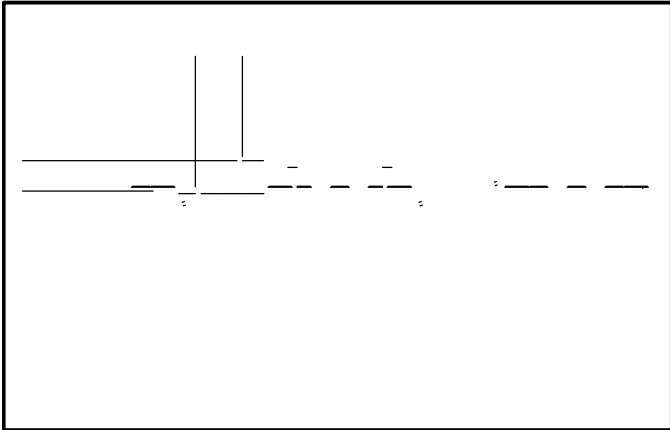

**FIGURE 11**

A proving switch connected to the combustion air inducer orifice plate is used to prove inducer operation. The combustion air inducer orifice will be different for each model. See table 10 for orifice sizes. The switch monitors air pressure in the inducer housing. During normal operation, the pressure in the housing is negative. If pressure becomes less negative (signifying an obstruction) the proving switch opens. When the proving switch opens, the furnace control (A92) immediately closes the gas valve to prevent burner operation.

**TABLE 10**

G50UHi Unit	C.A.I. Orifice Size
-070	1 7/16"
-090	1 11/16"
-110	2 5/32"
-135	2 3/8"

**Horizontal Applications**

The G50UHi furnace can be installed in horizontal applications.

The combustion air inducer may be rotated clockwise or counterclockwise by 90° to allow for vertical vent discharge in a horizontal application. Remove the four mounting screws, rotate the assembly (assembly consists of orifice plate, proving switch, gasket and combustion air inducer), then reinstall the mounting screws. See figure 14. Use the provided wire tie to bundle the pressure switch wires with the inducer motor power leads. **Route the wires away from moving parts and the heat of the inducer motor to prevent damage to the wires.** Use sheet metal shears to remove the cut out from the side of the cabinet. See figure 15. Use the two provided sheet metal screws to install the cut out on the top cap to cover the original flue outlet opening.

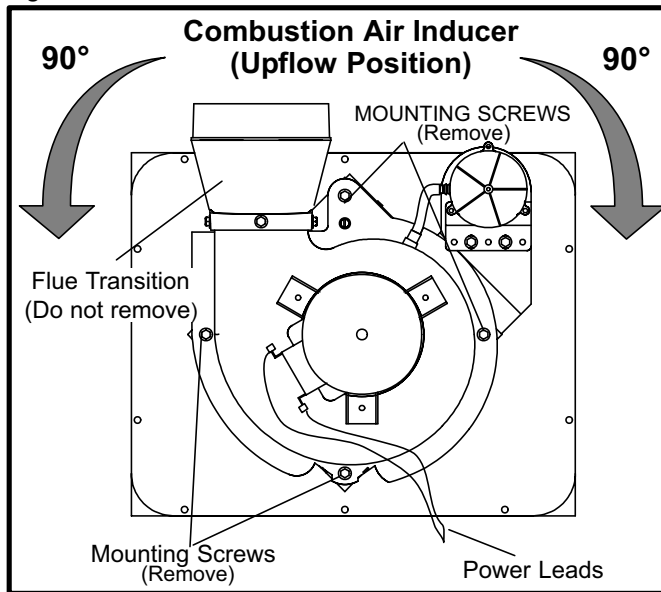

**FIGURE 14**

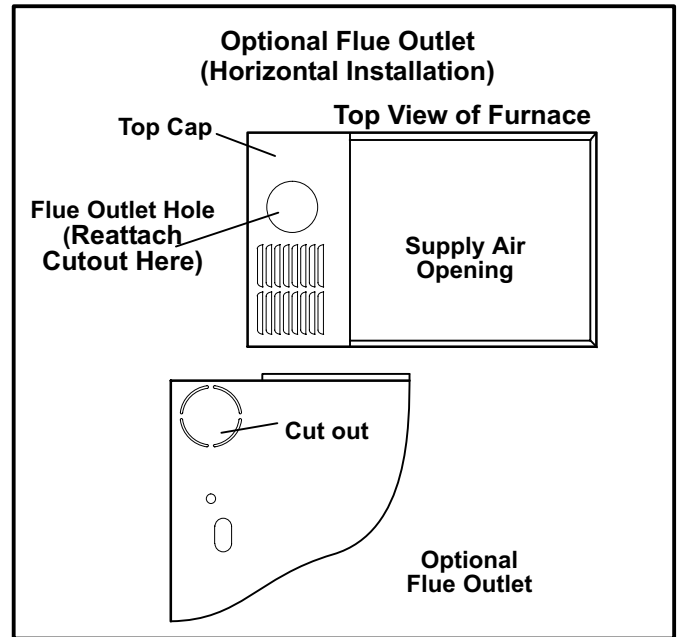

**FIGURE 15**

**10. Flame Rollout Switches (S47)**

Flame rollout switch is a high temperature limit located on top of the burner box (135 and 155 Btuh units- rollout switches are located on the inner sides of burner box). Each furnace is equipped with two identical switches. One switch is located over the far left burner and the other switch is located over the far right burner. The limit is a N.C. SPST manual-reset limit connected in series with the ignition control A92. When S47 senses rollout, the ignition control immediately stops ignition and closes the gas valve. If unit is running and flame rollout is detected, the gas valve will close and ignition control will be disabled. Rollout can be caused by a blocked heat exchanger, flue or lack of combustion air. The switch is factory set and cannot be adjusted. See table 11. The switch can be manually reset. To manually reset a tripped switch, push the reset button located on the control.

**TABLE 11**

BTUH INPUT	Rollout Switch Setpoint
-070	250° F
-090	
-110	
-135	200° F

### 11. Primary Limit Control (S10)

The primary limit (S10) on G50UHi units is located in the heating vestibule panel. When excess heat is sensed in the heat exchanger, the limit will open. If the limit is open, the furnace control energizes the supply air blower and closes the gas valve. The limit automatically resets when unit temperature returns to normal. The switch must reset within three minutes or SureLight board will go into Watch guard for one hour. The switch is factory set and cannot be adjusted. The switch may have a different setpoint for each unit model number. If limit switch must be replaced, see Lennox Repair Parts handbook.

### 12. Secondary Limit Controls (S21)

The secondary limit (S21) on G50UHi units is located in the blower compartment in the back side of the blower housing. See figure 13. Table 12 and the blower speed chart on the wiring diagram show secondary limit quantities per unit. When excess heat is sensed in the blower compartment, the limit will open. If the limit is open, the furnace control energizes the supply air blower and closes the gas valve. The limit automatically resets when unit temperature returns to normal. G50UHi-1 through -6 units use a surface type limit, factory set to open at 125°F. G50UHi -7 and later units use an air stream limit factory set to open at 135°. The secondary limit cannot be adjusted.

TABLE 12

G50UHi UNIT	Quantity	Left Side	Right Side
36A-070	2	Yes	Yes
36B-090	1	No	Yes
48B-090	2	Yes	Yes
60C-110	1	No	Yes
60D-135	2	Yes	Yes

### 13. Gas Valve (GV1) Figures 16, 17 & 18

The G50UHi uses a gas valve manufactured by Honeywell or White Rodgers. The valve is internally redundant to assure safety shut-off. If the gas valve must be replaced, the same type valve must be used.

24VAC terminals and gas control knob or switch are located on the valve. All terminals on the gas valve are connected to wires from the electronic ignition control. 24V applied to the terminals energizes the valve.

Inlet and outlet pressure taps are located on the valve. A regulator adjustment screw is located on the valve.

LPG changeover kits are available from Lennox. Kits include burner orifices and a gas valve regulator conversion kit.

### WHITE RODGERS 36E SERIES GAS VALVE

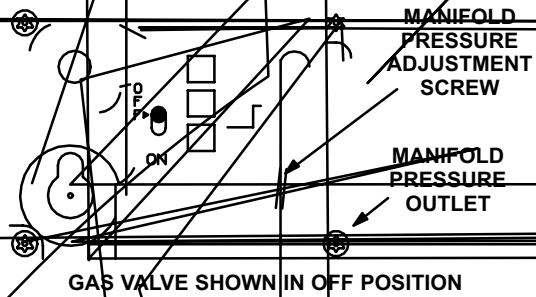

Set points vary depending on unit size. See table 13. The pressure sensed by the switch is negative relative to atmospheric pressure. If the flue becomes obstructed during operation, the switch senses a loss of negative pressure (pressure becomes more equal with atmospheric pressure) and opens the circuit to the furnace control and gas valve. A bleed port on the switch allows relatively dry air in the vestibule to purge switch tubing, to prevent condensate build up.

The switch is factory set and is not field adjustable. It is a safety shut-down control in the furnace and must not be by-passed for any reason. If switch is closed or by-passed, the control will not initiate ignition at start up.

**TABLE 13**

G50UHi Unit	Set Point	High Altitude Set Point 4501' - 7500'	High Altitude Set Point 7500' - 10,000'
-070	0.47"	0.36"	0.36"
-090	0.51"	0.47"	0.43"
-110	0.58"	0.47"	0.43"
-135	0.51"	0.47"	0.43"

## II-PLACEMENT AND INSTALLATION

Make sure unit is installed in accordance with installation instructions and applicable codes.

### III-START-UP

#### A-Preliminary and Seasonal Checks

- 1 - Inspect electrical wiring, both field and factory installed for loose connections. Tighten as required.
- 2 - Check voltage at disconnect switch. Voltage must be within range listed on the nameplate. If not, consult the power company and have voltage condition corrected before starting unit.

#### B-Heating Start-Up

**⚠ WARNING**

**Shock and burn hazard. G50UHi units are equipped with a hot surface ignition system. Do not attempt to light manually.**

- 1 - **STOP!** Read the safety information at the beginning of this section.
- 2 - Set thermostat to lowest setting.
- 3 - Turn off all electrical power to appliance.
- 4 - This appliance is equipped with an ignition device which automatically lights the burners. Do **not** try to light the burners by hand.
- 5 - Remove top access panel.
- 6 - *White Rodgers Gas Valve* -- Switch lever to **OFF**. See figure 16. *Honeywell Gas Valve* -- Turn knob on gas valve clockwise  to **OFF**. Do not force. See figure 18.

7 - Wait five (5) minutes to clear out any gas. If you then smell gas, **STOP!** Immediately call your gas supplier from a neighbor's phone. Follow the gas supplier's instructions. If you do not smell gas go to next step.

8 - *White Rodgers Gas Valve* -- Switch gas valve lever to **ON**.

*Honeywell Gas Valve* -- Turn knob on gas valve counterclockwise  to **ON**. Do not force.

9 - Replace access panel.

10- Turn on all electrical power to unit.

11- Set thermostat to desired setting.

12- If the appliance will not operate, follow the instructions "To Turn Off Gas To Unit" and call your service technician or gas supplier.

#### Turning Off Gas To Unit

- 1 - Set thermostat to lowest setting.
- 2 - Turn off all electrical power to unit if service is to be performed.
- 3 - Remove access panel.
- 4 - Switch lever on *White Rodgers* gas valve to **OFF**; turn knob on *Honeywell* valve clockwise  to **OFF**. Do not force.
- 5 - Replace access panel.

#### C-Safety or Emergency Shutdown

Turn off unit power. Close manual and main gas valves.

#### D-Extended Period Shutdown

Turn off thermostat or set to "UNOCCUPIED" mode. Close all gas valves (both internal and external to unit) to guarantee no gas leak into combustion chamber. Turn off power to unit. All access panels and covers must be in place and secured.

## IV-HEATING SYSTEM SERVICE CHECKS

#### A-C.S.A. Certification

All units are C.S.A. (formally A.G.A. and C.G.A. combined) design certified without modifications. Refer to the G50UHi Installation Instruction.

#### B-Gas Piping

**⚠ CAUTION**

**If a flexible gas connector is required or allowed by the authority that has jurisdiction, black iron pipe shall be installed at the gas valve and extend outside the furnace cabinet.**

**⚠ WARNING**

**Do not exceed 600 in-lbs (50 ft-lbs) torque when attaching the gas piping to the gas valve.**

Gas supply piping should not allow more than 0.5"W.C. drop in pressure between gas meter and unit. Supply gas pipe must not be smaller than unit gas connection

Compounds used on gas piping threaded joints should be resistant to action of liquefied petroleum gases.

## C-Testing Gas Piping

### ⚠ IMPORTANT

In case emergency shutdown is required, turn off the main shut-off valve and disconnect the main power to unit. These controls should be properly labeled by the installer.

When pressure testing gas lines, the gas valve must be disconnected and isolated. Gas valves can be damaged if subjected to more than 0.5psig (14" W.C.). See figure 19. If the pressure is equal to or less than 0.5psig (14"W.C.), use the manual shut-off valve before pressure testing to isolate furnace from gas supply.

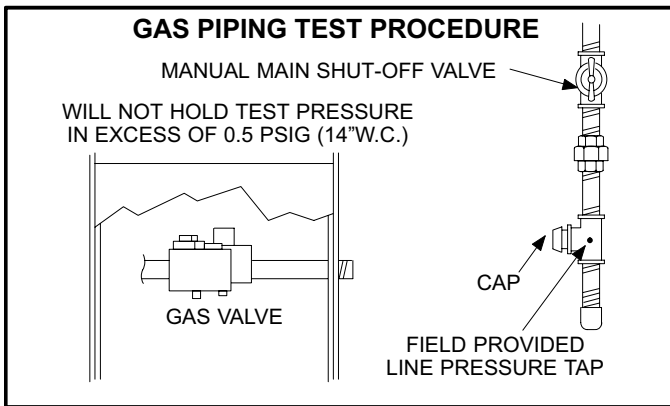

FIGURE 19

When checking piping connections for gas leaks, use preferred means. Kitchen detergents can cause harmful corrosion on various metals used in gas piping. Use of a specialty Gas Leak Detector is strongly recommended. It is available through Lennox under part number 31B2001. See Corp. 8411-L10, for further details.

Do not use matches, candles, flame or any other source of ignition to check for gas leaks.

## D-Testing Gas Supply Pressure

When testing supply gas pressure, connect test gauge to inlet pressure tap (field provided). See figure 19. Check gas line pressure with unit firing at maximum rate. Low pressure may result in erratic operation or underfire. High pressure can result in permanent damage to gas valve or overfire. See table 14 for operating pressure at unit gas connection (line).

On multiple unit installations, each unit should be checked separately, with and without units operating. Supply pressure must fall within range listed in previous paragraph.

## E-Check Manifold Pressure

After line pressure has been checked and adjusted, check manifold pressure. Move pressure gauge to outlet pressure tap located on unit gas valve (GV1). Checks of manifold pressure are made as verification of proper regulator adjustment. Manifold pressure for the G50UHi can be measured at any time the gas valve is open and is supplying gas to the unit. See table 14 for normal operating manifold pressure. See page 2 for high altitude applications.

TABLE 14

All G50UHi Units	Natural	LP
Line Pressure WC"	4.5 - 10.5	11.0 - 13.0
Manifold Pressure WC"	3.5	10.0

### ⚠ IMPORTANT

For safety, connect a shut-off valve between the manometer and the gas tap to permit shut off of gas pressure to the manometer.

The gas valve is factory set and should not require adjustment. All gas valves are factory regulated. See specifications section of this manual for High Altitude manifold pressure settings.

### Manifold Adjustment Procedure:

- 1 - Connect a test gauge to outlet pressure tap on gas valve. See figures 16, 17 and 18. Start unit and allow 5 minutes for unit to reach steady state.
- 2 - While waiting for the unit to stabilize, notice the flame. Flame should be stable and should not lift from burner. Natural gas should burn blue. L.P. gas should burn mostly blue with some orange streaks.
- 3 - After allowing unit to stabilize for 5 minutes, record manifold pressure.

*NOTE-Shut unit off and remove manometer as soon as an accurate reading has been obtained. Take care to replace pressure tap plug.*

## F- Proper Gas Flow (Approximate)

Furnace should operate at least 5 minutes before checking gas flow. Determine time in seconds for **two** revolutions of gas through the meter. (Two revolutions assures a more accurate time.) **Divide by two** and compare to time in table 15 below. If manifold pressure matches table 14 and rate is incorrect, check gas orifices for proper size and restriction.

*NOTE- To obtain accurate reading, shut off all other gas appliances connected to meter.*

TABLE 15

GAS METER CLOCKING CHART				
G50UH Unit	Seconds for One Revolution			
	Natural		LP	
	1 cu ft Dial	2 cu ft Dial	1 cu ft Dial	2 cu ft DIAL
-70	55	110	136	272
-90	41	82	102	204
-110	33	66	82	164
-135	27	54	68	136
Natural-1000 btu/cu ft			LP-2500 btu/cu ft	

**! IMPORTANT**

For safety, shut unit off and remove manometer as soon as an accurate reading has been obtained. Take care to replace pressure tap plug.

**G- Proper Combustion**

Furnace should operate minimum 15 minutes with correct manifold pressure and gas flow rate before checking combustion. See sections E- and F-. Take combustion sample beyond the flue outlet and compare to table 16. The maximum carbon monoxide reading should not exceed 100 ppm.

TABLE 16

Unit	CO <sub>2</sub> % For Nat	CO <sub>2</sub> % For L.P.
G50UHi-36A-070	5.8 - 7.8	6.8 - 8.8
G50UHi-36B-090	6.2 - 8.2	6.7 - 8.7
G50UHi-48B-090	6.2 - 8.2	6.7 - 8.7
G50UHi-60C-110	5.9 - 7.9	7.5 - 9.5
G50UHi-60D-135	6.5 - 8.5	7.5 - 9.5

**H-Flame Signal**

A microamp DC meter is needed to check the flame signal on the ignition control.

Flame (microamp) signal is an electrical current which passes from the furnace control through the sensor during unit operation. Current passes from the sensor through the flame to ground to complete a safety circuit.

TABLE 17

Flame Signal in Microamps			
Ignition Control	Normal	Low	Drop Out
97L48	≥ 0.61	0.21 - 0.60	≤ 0.20
69M15	≥ 0.31	0.25 - 0.30	≤ 0.24

**To Measure Flame Signal - Ignition Control:**

A transducer (Part #78H5401 available from Lennox Repair Parts) is required to measure flame signal if meter used will not read a low micro amp signal. See figure 20. The transducer converts microamps to volts on a 1:1 conversion. See table 17 for flame signal. A digital readout meter must be used. The transducer plugs into most meters. See figure 21 for proper use of transducer.

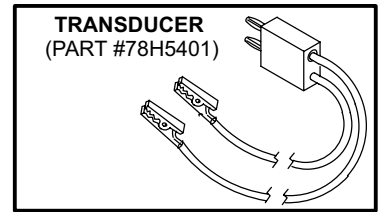

FIGURE 20

- 1 - Set the volt meter to the DC voltage scale. Insert transducer into the VDC and common inputs. Observe correct polarities. Failure to do so results in negative (-) values.
- 2 - Turn off supply voltage to control.
- 3 - Disconnect ignition control flame sensor wire from the flame sensor.
- 4 - Connect (-) lead of the transducer to flame sensor.
- 5 - Connect (+) lead of transducer to the ignition control sensor wire.
- 6 - Turn supply voltage on and close thermostat contacts to cycle system.
- 7 - When main burners are in operation for two minutes, take reading. Remember 1 DC volt = 1 DC microamp.

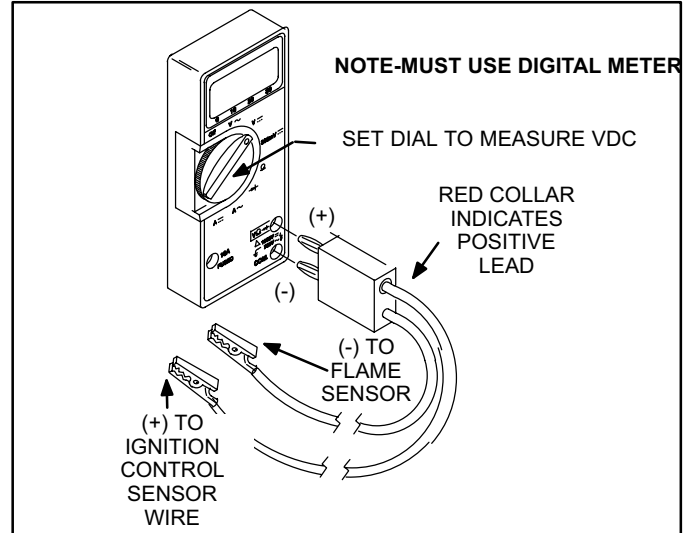

FIGURE 21

## V-TYPICAL OPERATING CHARACTERISTICS

### A-Blower Operation and Adjustment

- 1 - Blower operation is dependent on thermostat control system.
- 2 - Generally, blower operation is set at thermostat sub-base fan switch. With fan switch in ON position, blower operates continuously. With fan switch in AUTO position, blower cycles with demand or runs continuously while heating or cooling circuit cycles.
- 3 - Depending on the type of indoor thermostat, blower and entire unit will be off when the system switch is in OFF position.

### B-Temperature Rise

Temperature rise for G50UHi units depends on unit input, blower speed, blower horsepower and static pressure as marked on the unit rating plate. The blower speed must be set for unit operation within the range of "TEMP. RISE °F" listed on the unit rating plate.

#### To Measure Temperature Rise:

- 1 - Place plenum thermometers in the supply and return air plenums. Locate supply air thermometer in the first horizontal run of the plenum where it will not pick up radiant heat from the heat exchanger.
- 2 - Set thermostat to highest setting.
- 3 - After plenum thermometers have reached their highest and steadiest readings, subtract the two readings. The difference should be in the range listed on the unit rating plate. If the temperature is too low, decrease blower speed. If temperature is too high, first check the firing rate. Provided the firing rate is acceptable, increase blower speed to reduce temperature.

### C-External Static Pressure

- 1 - Tap locations shown in figure 22 .

- 2 - Punch a 1/4" diameter hole in supply and return air plenums. Insert manometer hose flush with inside edge of hole or insulation. Seal around the hose with perma-gum. Connect the zero end of the manometer to the discharge (supply) side of the system. On ducted systems, connect the other end of manometer to the return duct as above. For systems with non-ducted returns, leave the other end of the manometer open to the atmosphere.

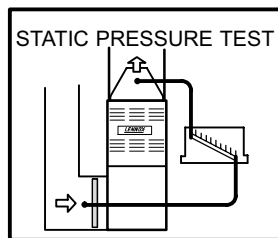

FIGURE 22

- 3 - With only the blower motor running and the evaporator coil dry, observe the manometer reading. Adjust blower motor speed to deliver the air desired according to the job requirements.
- 4 - External static pressure drop must not be more than 0.5" W.C.
- 5 - Seal around the hole when the check is complete.

## VI-MAINTENANCE

### ⚠ WARNING

Disconnect power before servicing unit.

### ⚠ CAUTION

Label all wires prior to disconnection when servicing controls. Wiring errors can cause improper and dangerous operation. Verify proper operation after servicing.

At the beginning of each heating season, a qualified technician should check the system as follows:

#### Blower

Check the blower wheel for debris and clean if necessary. The blower motors are prelubricated for extended bearing life. No further lubrication is needed.

### ⚠ WARNING

The blower access panel must be securely in place when the blower and burners are operating. Gas fumes, which could contain carbon monoxide, can be drawn into living space resulting in personal injury or death.

#### Filters

All G50UHi filters are installed external to the unit. Filters should be inspected monthly. Clean or replace the filters when necessary to ensure that the furnace operates properly. Replacement filters must be rated for high velocity airflow. Table 18 lists recommended filter sizes.

TABLE 18

Furnace Cabinet Size	Filter Size	
	Side Return	Bottom Return
14-1/2"	16 X 25 X 1 (1)	14 X 25 X 1 (1)
17-1/2"	16 X 25 X 1 (1)	16 X 25 X 1 (1)
21"	16 X 25 X 1 (1)	20 X 25 X 1 (1)
24-1/2"	16 X 25 X 1 (2)	24 X 25 X 1 (1)

#### Flue And Chimney

Check the flue pipe, chimney and all connections for tightness and to make sure there is no blockage.

#### Electrical

- 1 - Check all wiring for loose connections.
- 2 - Check for the correct voltage at the furnace (furnace operating).
- 3 - Check amp-draw on the blower motor.  
Motor Nameplate \_\_\_\_\_ Actual \_\_\_\_\_

## Cleaning the Heat Exchanger and Burners

### **⚠ WARNING**

**Safety glasses should be worn when cleaning heat exchanger**

*NOTE - Use papers or protective covering in front of the furnace during cleaning.*

Cleaning the heat exchanger requires a steel spring "snake," a reversible drill and a vacuum cleaner. The steel spring snake may be constructed by purchasing a 4 ft. long by 1/4 inch diameter steel wire cable and a 1/4 inch diameter wire brush. These items are available at a hardware store. Insert wire end of brush into the open end of the spring cable. Crimp the cable around the brush so that the brush is secured and will not come off during cleaning. Attach the other end of the cable to the reversible drill to complete the tool for cleaning the heat exchanger.

- 1 - Turn off both electrical and gas power supplies to furnace.
- 2 - Remove flue pipe and top cap from the unit. Label the pressure switch wires, then disconnect them.
- 3 - Remove the four screws that secure the combustion air inducer. Carefully remove the combustion air inducer to avoid damaging blower gasket. If gasket is damaged, it must be replaced to prevent leakage.

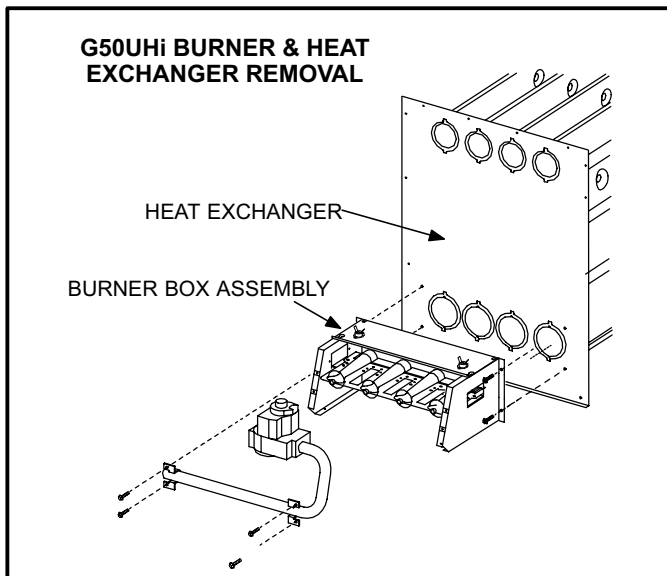

**FIGURE 23**

- 4 - Remove the collector box located behind the combustion air inducer. Be careful with the collector box gasket. If the gasket is damaged, it must be replaced to prevent leakage.
- 5 - Label the wires from gas valve and rollout switches, then disconnect them.
- 6 - Disconnect gas supply piping. Remove four screws securing the burner manifold assembly to the vestibule panel and remove the assembly from the unit.

- 7 - Insert the brush end of cable snake into the top of one of the heat exchanger openings. **Do not force the cable into the heat exchanger.** Insert the cable and operate the drill on slow speed. Move the cable in and out of the heat exchanger section three or four times or until sufficient cleaning is accomplished. Reverse drill and slowly work the cable out of opening.
- 8- Repeat procedure for each heat exchanger section.
- 9- After each of the top heat exchanger sections has been cleaned, insert the brush end of the cable snake into the bottom openings of each of the heat exchanger sections and clean as described in step 8.
- 10- Remove the cable from the heat exchanger. Use a vacuum cleaner to remove debris knocked loose during cleaning.
- 11- Attach the exhaust end (positive pressure) of the vacuum cleaner to the top of the heat exchanger section. Any loose debris will be forced to the bottom of the heat exchanger section. Vacuum debris from bottom openings.

**NOTE - Take care not to inhale loose debris. Surgical mask should be worn when using vacuum cleaner.**

- 12- Replace collector box and combustion air inducer. Check gaskets for damage. Damaged gaskets must be replaced to avoid heat exchanger leaks. Replace all screws to the collector box and combustion air inducer. Failure to replace all screws may cause leaks.
- 13- To clean the burner, run a vacuum cleaner with a soft brush attachment over the face of burners. Visually inspect inside the burners and crossovers for any blockage caused by foreign matter. Remove any blockage.
- 14- Replace burner/manifold assembly onto the vestibule panel.
- 15- Reconnect wires to pressure switch, roll-out switches, gas valve and combustion air inducer. Refer to unit wiring diagram.
- 16- Reconnect vent pipe to combustion air inducer outlet.
- 17- Reconnect gas supply piping.
- 18- Turn on power and gas supply to unit.
- 19- Set thermostat and check for proper operation.
- 20- Check all piping connections, factory and field, for gas leaks. Use a leak detecting solution or other preferred means.

### **⚠ CAUTION**

**Some soaps used for leak detection are corrosive to certain metals. Carefully rinse piping thoroughly after leak test has been completed. Do not use matches, candles, flame or other sources of ignition to check for gas leaks.**

- 21- If a leak is detected, shut gas and electricity off and repair leak.
- 22- Repeat steps 23 and 24 until no leaks are detected.
- 23- Replace front access panel.

# VII- WIRING AND SEQUENCE OF OPERATION

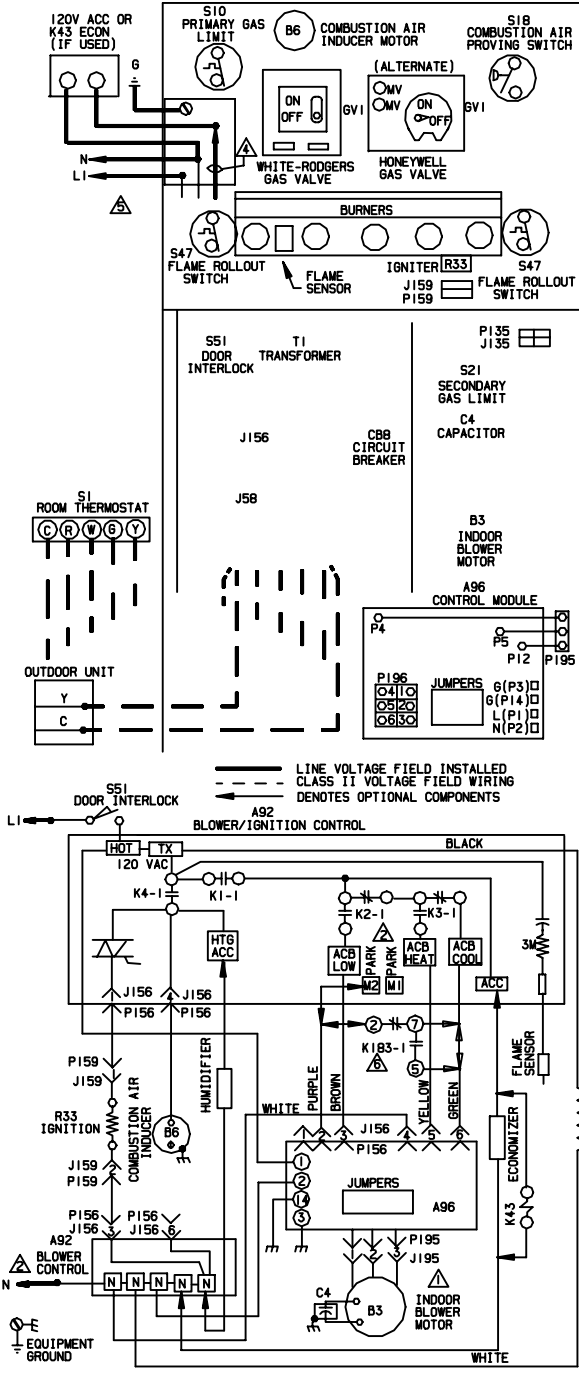

INDICATES DEFAULT JUMPER SETTING

SPEED	FACTORY JUMPER SETTINGS				DEHUM	AUTO RAMP
	COOL	HEAT 3 TON	4 & 5 TON	LOW (FAN)		
1	[HIGH]			HIGH		HIGH OFF
2	M HIGH	HIGH				[M HIGH 82%, 7.5 MIN]
3		M HIGH	HIGH			M LOW 75%, 10 MIN
4	M LOW	[M LOW]	M HIGH		[HIGH]	LOW 75%, 15 MIN
5	LOW	LOW	[M LOW]		M HIGH	
6			LOW	M HIGH	M LOW	
7				M LOW	LOW	
8				[LOW]		

**THERMOSTAT HEAT ANTICIPATION SETTINGS**  
 .65 AMP HONEYWELL VALVE  
 .50 AMP WHITE-RODGERS VALVE

JACKPLUG CHART	UNIT	SECONDARY LIMITS USED
J.P58 JACK/PLUG-BURNER CONTROL	36A-070	2
J.P135 JACK/PLUG-SECONDARY LIMIT	36B-090	1 (RIGHT)
J.P159 JACK/PLUG-IGNITION	48B-090	2
J.P195 JACK/PLUG-CONTROL MODULE	60C-110	1 (RIGHT)
J.P196 JACK/PLUG-BLOWER MOTOR	60D-135	2

**WARNING-**  
 ELECTRIC SHOCK HAZARD, CAN CAUSE INJURY OR DEATH. UNIT MUST BE GROUNDED IN ACCORDANCE WITH NATIONAL AND LOCAL CODES.

**NOTE-**  
 IF ANY WIRE IN THIS APPLIANCE IS REPLACED, IT MUST BE REPLACED WITH WIRE OF LIKE SIZE, RATING, INSULATION THICKNESS AND TERMINATION.

**IMPORTANT-**  
 TO PREVENT MOTOR BURNOUT, NEVER CONNECT MORE THAN ONE MOTOR LEAD TO ANY ONE CONNECTION.

**PARK TERMINALS ARE UNPOWERED TERMINALS. ALL UNUSED MOTOR LEADS MUST BE WIRED TO A PARK TERMINAL.**

**FOR CORRECT NUMBER OF SECONDARY LIMITS USED, SEE SECONDARY LIMIT SECTION OF BLOWER SPEED CHART.**

**FIELD SUPPLIED ACC. WIRE.**

**USE COPPER CONDUCTORS ONLY.**

**TERMINAL D OFF FOR DEHUMIDIFICATION. TERMINAL D ON FOR NORMAL COOLING.**

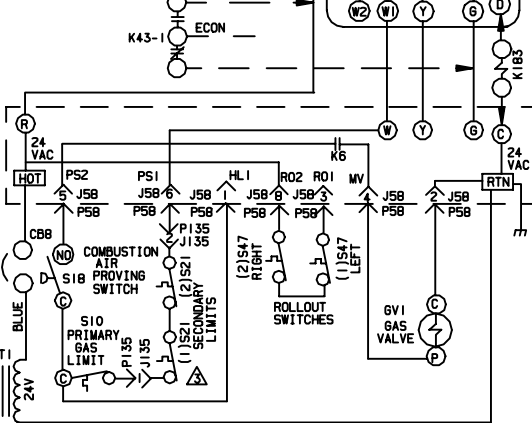
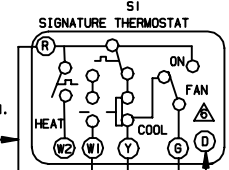

**LENNOX HEATING UNITS-GAS**

G50UHI-36A-070-6,7	G50UHI-60C-110-6,7
G50UHI-36B-090-6,7	G50UHI-60D-135-6,7
G50UHI-48B-090-6,7	
0903	Supersedes 534, 498W
	New Form No. 534, 544W

©2003 Lennox Industries Inc. Litho U.S.A.

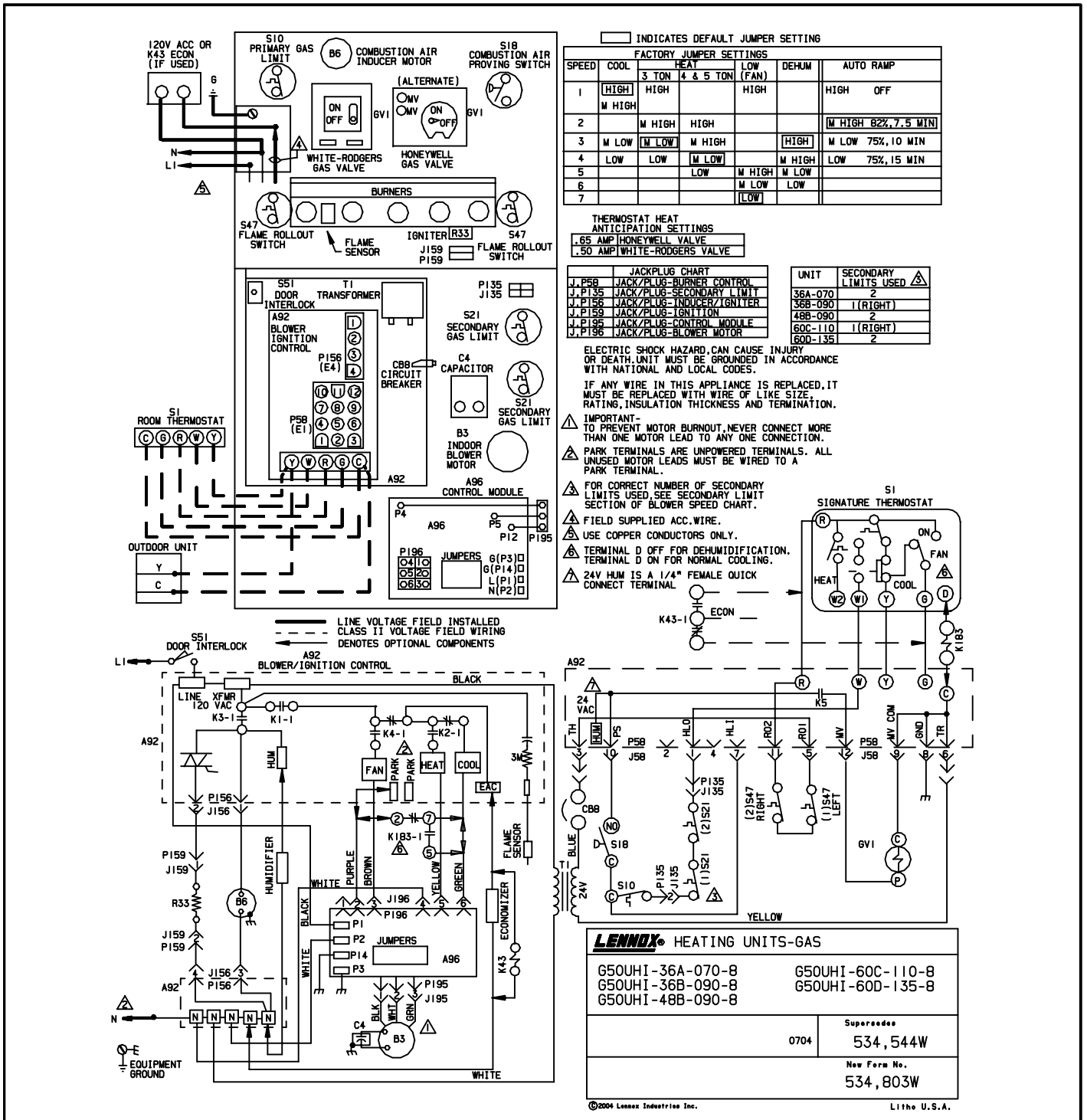

### G50UHi-8

- 1 - When there is a call for heat, W1 of the thermostat energizes W of the furnace control with 24VAC.
- 2 - S10 primary limit switch, S47 rollout switch and S21 secondary limit are closed. Call for heat can continue.
- 3 - SureLight control (A92) energizes combustion air inducer B6. Combustion air inducer runs until S18 combustion air prove switch closes (switch must close within 2-1/2 minutes or control goes into 5 minute Watchguard Pressure Switch delay). Once S18 closes, a 15-second pre-purge follows.
- 4 - SureLight control (A92) energizes ignitor. A 20-second warm-up period begins.

- 5 - Gas valve opens for a 4-second trial for ignition.
- 6 - Flame is sensed, gas valve remains open for the heat call.
- 7 - After 45-second delay, SureLight control (A92) energizes indoor blower B3.
- 8 - When heat demand is satisfied, W1 of the indoor thermostat de-energizes W of the SureLight control which de-energizes the gas valve. Combustion air inducer B6 continues a 5-second post-purge period, and indoor blower B3 completes a selected OFF time delay.

## SURELIGHT CONTROL HEATING SEQUENCE OF OPERATION

Control board 69M15 LED #1 = DS1, LED #2 = DS2  
Control board 97L48 LED #1 = DIAG1 LED #2 = DIAG2

### NORMAL HEATING MODE

### ABNORMAL HEATING MODE

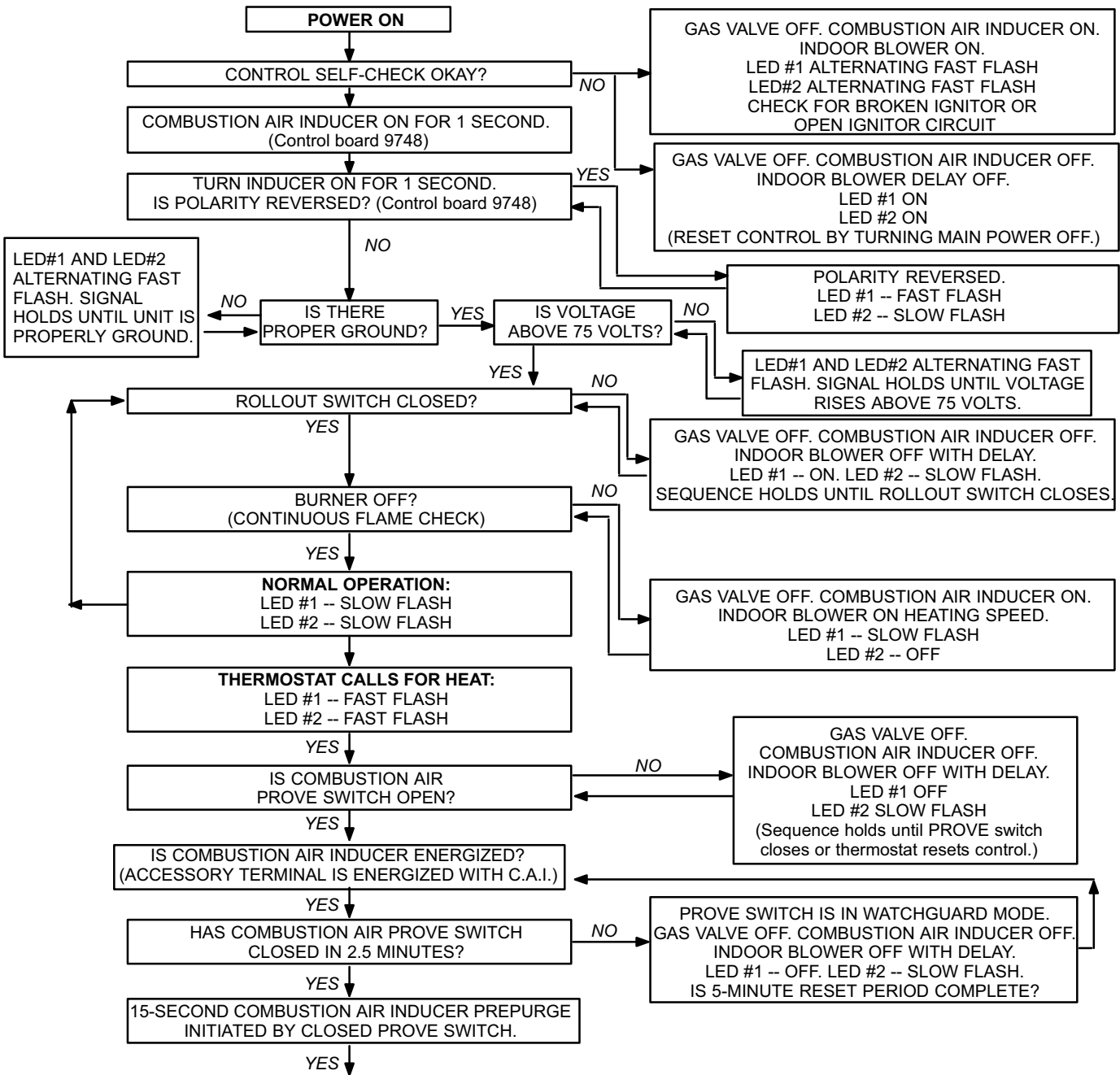

CONTINUED NEXT PAGE

**TABLE 19  
FLAME SENSE SIGNAL**

SureLight Control Board	Normal	Low	Drop Out
97L48	≥0.61	0.21 - 0.60	0.20
69M15	≥0.31	0.25 - 0.30	0.24

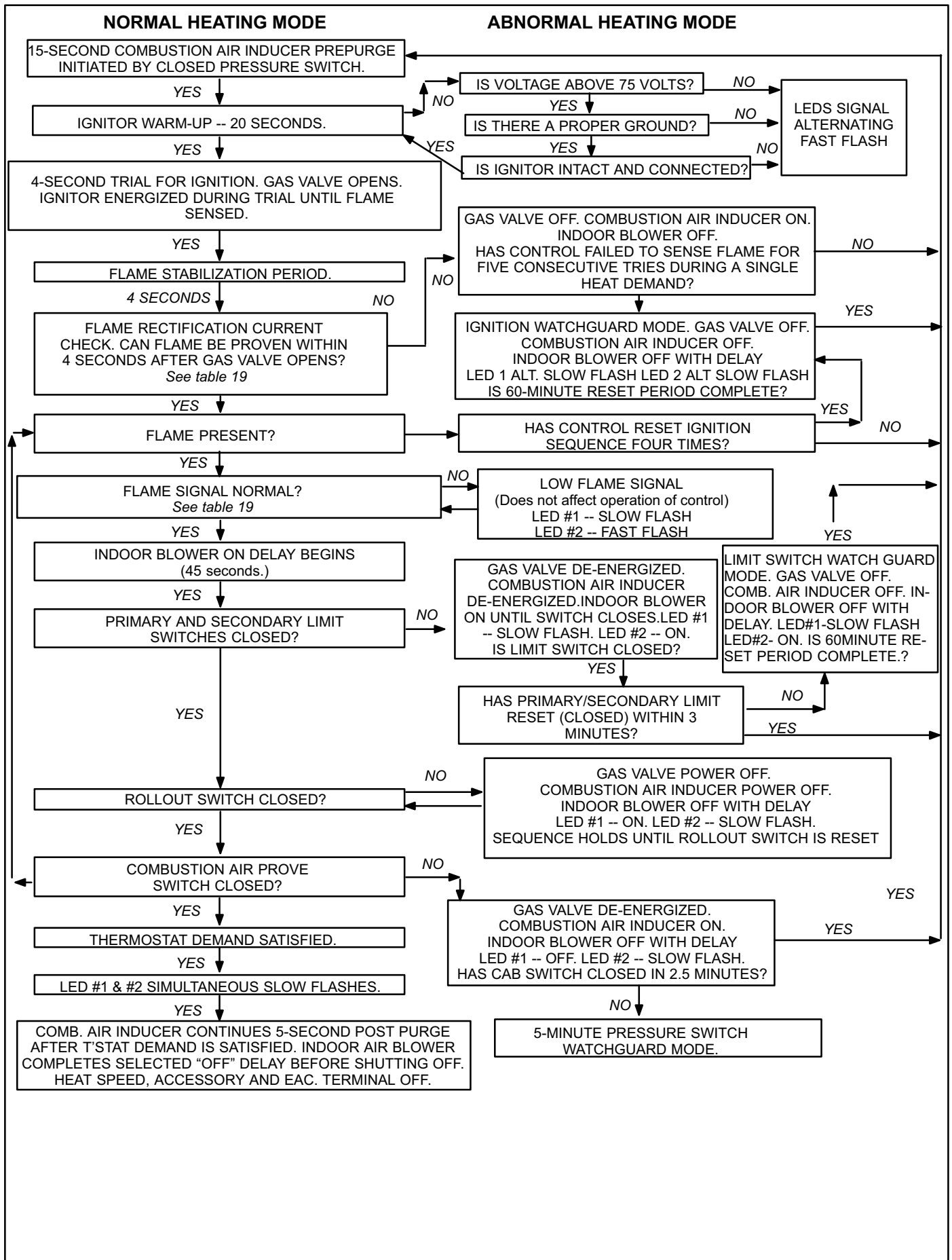

## SURELIGHT CONTROL COOLING SEQUENCE OF OPERATION

### NORMAL COOLING MODE

### ABNORMAL COOLING MODE

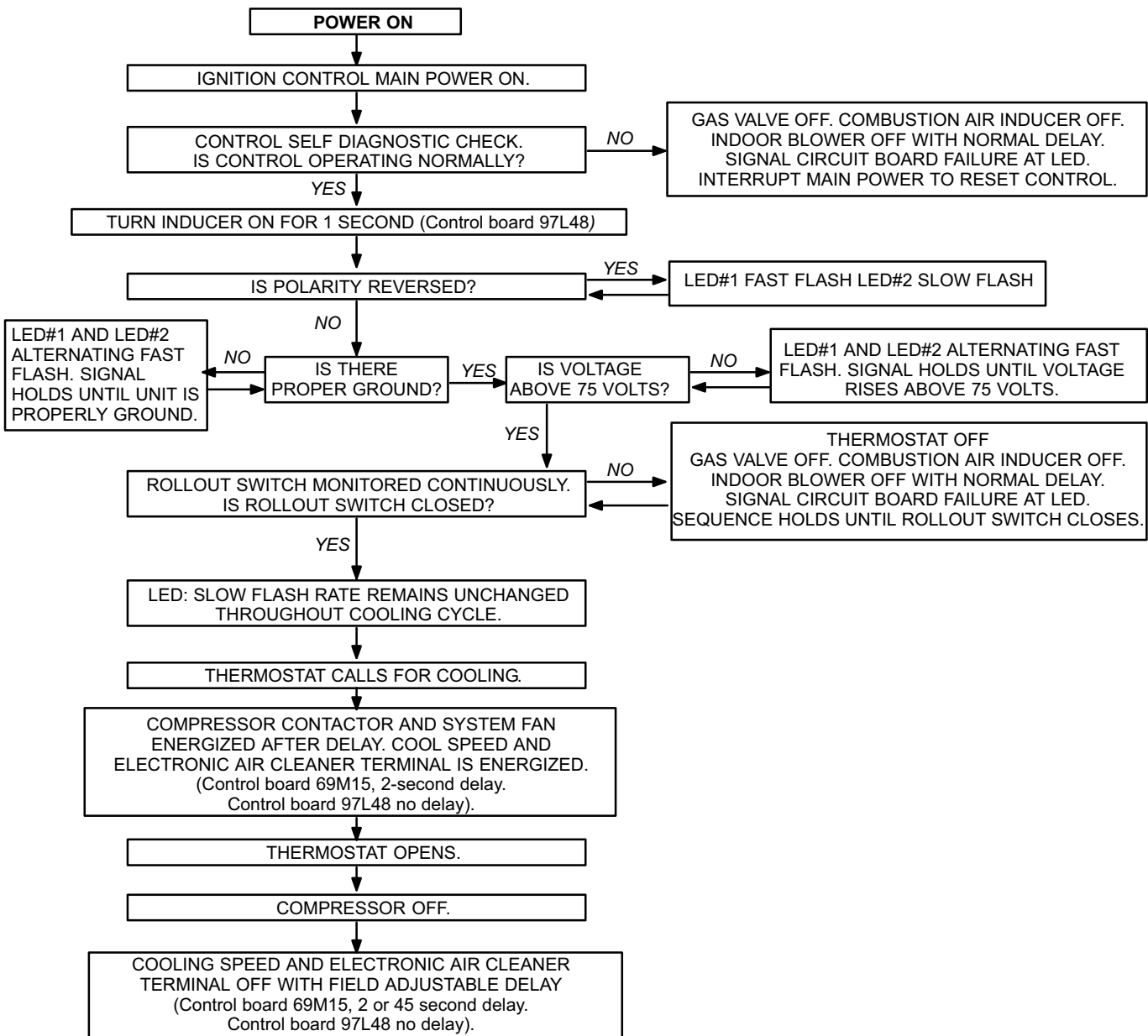

## SURELIGHT CONTROL CONTINUOUS FAN SEQUENCE OF OPERATION

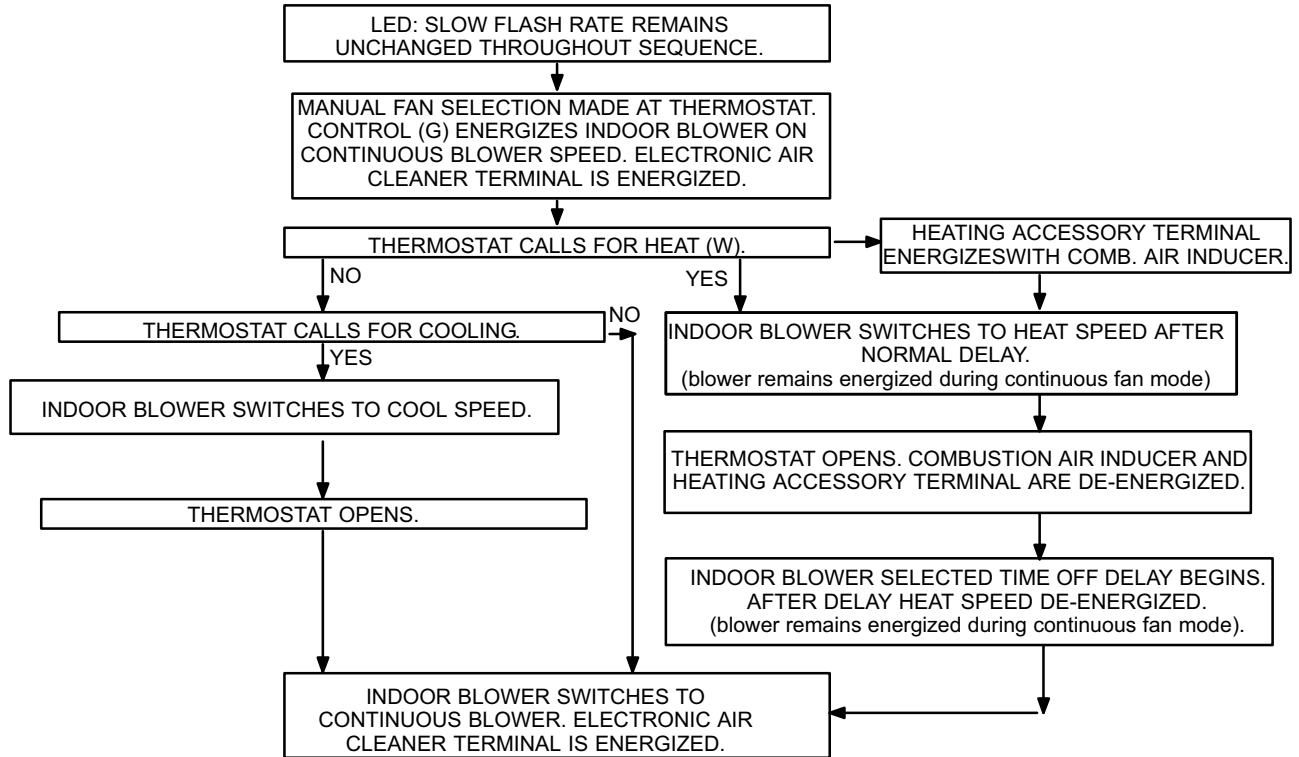

## VIII- TROUBLESHOOTING

### A-SureLight Control

UPON INITIAL POWER UP, REMOVE ALL THERMOSTAT DEMANDS TO THE UNIT

<b>PROBLEM: 1 UNIT FAILS TO OPERATE IN THE COOLING, HEATING, OR CONTINUOUS FAN MODE</b>		
<b>Condition</b>	<b>Possible Cause</b>	<b>Corrective Action / Comments</b>
<p><b>1.1</b></p> <p>- Both diagnostic lights fail to light up.</p> <p>LED#1-Off LED#2-Off</p>	<p><b>1.1.1</b></p> <p>Main voltage 120V not supplied to unit.</p>	<p><b>ACTION 1</b> - Check 120V main voltage. Determine cause of main power failure.</p>
	<p><b>1.1.2</b></p> <p>Miswiring of furnace or improper connections.</p>	<p><b>ACTION 1</b> - Check for correct wiring of 120V to power make up box and transformer. <b>ACTION 2</b> - Check 24V wiring to control board.</p>
	<p><b>1.1.3</b></p> <p>Circuit breaker tripped or fails to close.</p>	<p><b>ACTION 1</b> - Replace circuit breaker if it is reset but does not have continuity. <b>ACTION 2</b> - If circuit breaker still trips, check for short.</p>
	<p><b>1.1.4</b></p> <p>Door interlock switch failure.</p>	<p><b>ACTION 1</b> - Check that door switch is activated when door is closed. <b>ACTION 2</b> - Check wire connections to switch, replace loose connectors. <b>ACTION 3</b> - Check continuity of switch in closed position. Replace if defective.</p>
	<p><b>1.1.5</b></p> <p>Transformer Failure.</p>	<p><b>ACTION 1</b> - Check that transformer output is 24V. Replace if defective.</p>
	<p><b>1.1.6</b></p> <p>Failed control board.</p>	<p><b>ACTION 1</b> - If all the above items have been checked, replace board.</p>
<p><b>1.2</b></p> <p>- Diagnostic lights flash the roll-out code.</p> <p>LED#1-On, LED#2-Slow Flash</p>	<p><b>1.2.1</b></p> <p>Roll-out switch open.</p>	<p><b>ACTION 1</b> - Manually reset the roll-out switch by pushing the top button. <b>ACTION 2</b> - Determine the cause of the roll-out switch activation before leaving furnace.</p>
	<p><b>1.2.2</b></p> <p>Roll-out switch failure.</p>	<p><b>ACTION 1</b> - Check continuity across roll-out switch. Replace roll-out switch if switch is reset but does not have continuity.</p>
	<p><b>1.2.3</b></p> <p>Miswiring or improper connections at roll-out switch.</p>	<p><b>ACTION 1</b> - Check wiring connections to switch.</p>
	<p><b>1.2.4</b></p> <p>Nine pin connector failure</p>	<p><b>ACTION 1</b> - Check 9-pin connector for proper connection to control board. <b>ACTION 2</b> - Check continuity of the multi plug pin.</p>
<p><b>1.3</b></p> <p>- On initial power-up the comb. air inducer does not energize. - Diagnostic lights flash the reverse polarity code.</p> <p>LED#1-Fast Flash, LED#2-Slow Flash.</p>	<p><b>1.3.1</b></p> <p>120V main power polarity reversed.</p>	<p><b>ACTION 1</b> - Check the 120V has line and neutral correctly input into control. <b>ACTION 2</b> - Reverse the line and neutral at the 120V field connection.</p>
<p><b>1.4</b></p> <p>- On initial power up the combustion air inducer does not energize. - Diagnostic lights flash normal power on operation.</p> <p>LED#1-Slow Flash LED#2-Slow Flash</p>	<p><b>1.4.1</b></p> <p>Open combustion air inducer motor circuit.</p>	<p><b>ACTION 1</b> - Check for 120V to combustion air inducer. If no power, check wire and connections.</p>
	<p><b>1.4.2</b></p> <p>Failed combustion air inducer motor.</p>	<p><b>ACTION 1</b> - If power is present at blower, replace blower.</p>

<b>PROBLEM 1: UNIT FAILS TO OPERATE IN THE COOLING, HEATING, OR CONTINUOUS FAN MODE</b>		
<b>Condition</b>	<b>Possible Cause</b>	<b>Corrective Action / Comments</b>
<p><b>1.5</b></p> <ul style="list-style-type: none"> <li>- On initial power-up the combustion air blower remains energized.</li> <li>- Diagnostic lights flash the improper main ground.</li> </ul> <p>LED#1-Alternating Fast Flash LED#2-Alternating Fast Flash</p>	<p><b>1.5.1</b></p> <p>Improper ground to the unit.</p>	<p><b>ACTION 1</b> - Check that the unit is properly ground.</p> <p><b>ACTION 2</b> - Install a proper main ground to the unit</p>
	<p><b>1.5.2</b></p> <p>6-Pin connector is improperly attached to the circuit board.</p>	<p><b>ACTION 1</b> - Check 6-pin connector for proper installation. Correctly insert connector into control.</p>
	<p><b>1.5.3</b></p> <p>Line voltage is below 75V.</p>	<p><b>ACTION 1</b> - Check that the line voltage is above 75V. Determine cause of voltage drop and supply correct voltage to the control.</p>
<b>PROBLEM 2: UNIT WILL OPERATE IN COOLING BUT NOT IN THE HEATING MODE, WITH COMBUSTION AIR INDUCER CYCLING 5 SECONDS ON 55 SECONDS OFF.</b>		
<b>Condition</b>	<b>Possible Cause</b>	<b>Corrective Action / Comments</b>
<p><b>2.1</b></p> <ul style="list-style-type: none"> <li>- On initial power-up the combustion air inducer remains energized.</li> <li>- Diagnostic lights flash the improper main ground.</li> <li>- Units with control boards date coded after Nov.1 1997; combustion air inducer will cycle 5 seconds on 55 seconds off.</li> </ul> <p>LED#1-Alternating Fast Flash LED#2-Alternating Fast Flash</p>	<p><b>2.1.1</b></p> <p>Open ignitor circuit.</p>	<p><b>ACTION 1</b> - Check for correct wiring and loose connections in the ignitor circuit. Check multi-plug connections for correct installation.</p>
	<p><b>2.1.2</b></p> <p>Broken or failed ignitor.</p>	<p><b>ACTION 1</b> - Unplug ignitor and read resistance across ignitor. If resistance does not read between 10.9 and 19.7 ohms, replace the ignitor.</p>
<b>PROBLEM 3: UNIT FAILS TO FIRE IN THE HEATING MODE, COMBUSTION AIR BLOWER DOES NOT ENERGIZE</b>		
<b>Condition</b>	<b>Possible Cause</b>	<b>Corrective Action / Comments</b>
<p><b>3.1</b></p> <ul style="list-style-type: none"> <li>- Unit operates with a cooling or continuous fan demand.</li> <li>- Combustion air inducer will not start with a Heating demand.</li> <li>- Diagnostic lights flash the limit failure mode.</li> </ul> <p>LED#1-Slow Flash, LED#2-On</p>	<p><b>3.1.1</b></p> <p>Primary or secondary (if equipped ) limit open.</p>	<p><b>ACTION 1</b> - Check continuity across switch(es). Switches reset automatically upon cool down.</p> <p><b>ACTION 2</b> - Check for restrictions on blower inlet air (including filter) and outlet air. Determine cause for limit activation before placing unit back in operation.</p>
	<p><b>3.1.2</b></p> <p>Miswiring of furnace or improper connections at limit switch(es).</p>	<p><b>ACTION 1</b> - Check for correct wiring and loose connections. Correct wiring and/or replace any loose connections.</p>
<p><b>3.2</b></p> <ul style="list-style-type: none"> <li>- Unit operates with a cooling and continuous fan demand.</li> <li>- Combustion air inducer will not start with a Heating demand.</li> <li>- Diagnostic lights flash the pressure switch failure code.</li> </ul> <p>LED#1-Off, LED#2-Slow Flash</p>	<p><b>3.2.1</b></p> <p>Miswiring of furnace or improper connections to combustion air inducer.</p>	<p><b>ACTION 1</b> - Check for correct wiring and loose connections. Correct wiring and/or replace any loose connections.</p>
	<p><b>3.2.2</b></p> <p>Prove switch stuck closed.</p>	<p><b>ACTION 1</b> - Check that the prove switch is open without the combustion air inducer operating. Replace if defective.</p>

**PROBLEM 3: UNIT FAILS TO FIRE IN THE HEATING MODE, COMBUSTION AIR INDUCER DOES NOT ENERGIZE (CONT.).**

Condition	Possible Cause	Corrective Action/Comments
<p align="center"><b>3.3</b></p> <ul style="list-style-type: none"> <li>- Unit operates with a cooling and continuous fan demand.</li> <li>- Combustion air inducer will not start with a Heating demand.</li> <li>- Diagnostic lights flash the pressure switch failure code 2.5 minutes after heating demand.</li> </ul> <p>LED#1-Off, LED#2-Slow Flash</p>	<p><b>3.3.1</b></p> <p>Miswiring of furnace or improper connections to combustion air inducer.</p>	<p><b>ACTION 1</b> - Check for correct wiring and loose connections. Correct wiring and/or replace any loose connections.</p>
	<p><b>3.3.2</b></p> <p>Combustion air inducer failure.</p>	<p><b>ACTION 1</b> - If there is 120V to combustion air inducer and it does not operate, replace combustion air inducer.</p>

**PROBLEM 4: UNIT FAILS TO FIRE IN THE HEATING MODE, COMBUSTION AIR BLOWER ENERGIZES, IGNITOR IS NOT ENERGIZED.**

Condition	Possible Cause	Corrective Action/Comments
<p align="center"><b>4.1</b></p> <ul style="list-style-type: none"> <li>- Unit operates with a cooling and continuous fan demand.</li> <li>- Combustion air inducer energizes with a heating demand.</li> <li>- Diagnostic lights flash the pressure switch failure code 2.5 minutes after heating demand.</li> </ul> <p>LED#1-Off LED#2-Slow Flash</p>	<p><b>4.1.1</b></p> <p>Prove switch does not close due to incorrect routing of the pressure switch lines.</p>	<p><b>ACTION 1</b> - Check that the prove switch lines are correctly routed. Correctly route pressure switch lines.</p>
	<p><b>4.1.2</b></p> <p>Prove switch does not close due to obstructions in the pressure lines.</p>	<p><b>ACTION 1</b> - Remove any obstructions from the the prove lines and/or taps.</p>
	<p><b>4.1.3</b></p> <p>Prove switch lines damaged</p>	<p><b>ACTION 1</b> - Check prove switch lines for leaks. Replace any broken lines.</p>
	<p><b>4.1.4</b></p> <p>Condensate in prove switch line.</p>	<p><b>ACTION 1</b> - Check prove switch lines for condensate. Remove condensate from lines.</p>
	<p><b>4.1.5</b></p> <p>Prove switch does not close due to a low differential pressure across the prove switch.</p>	<p><b>ACTION 1</b> - Check the differential pressure across the prove switch. This pressure should exceed the set point listed on the switch. <b>ACTION 2</b> - Check for restricted inlet vent. Remove all blockage. <b>ACTION 3</b> - Check for proper vent sizing and run length. See installation instructions.</p>
	<p><b>4.1.6</b></p> <p>Wrong prove switch installed in the unit, or prove switch is out of calibration.</p>	<p><b>ACTION 1</b> - Check that the proper prove switch is installed in the unit. Replace prove switch if necessary.</p>
	<p><b>4.1.7</b></p> <p>Miswiring of furnace or improper connections at prove switch.</p>	<p><b>ACTION 1</b> - Check for correct wiring and loose connections. Correct wiring and/or replace any loose connections.</p>
	<p><b>4.1.8</b></p> <p>Prove switch failure.</p>	<p><b>ACTION 1</b> - If all the above modes of failure have been checked, the prove switch may have failed. Replace prove switch and determine if unit will operate.</p>

**PROBLEM 5: UNIT FAILS TO FIRE IN THE HEATING MODE, COMBUSTION AIR BLOWER ENERGIZES, IGNITOR IS ENERGIZED.**

Condition	Possible Cause	Corrective Action/Comments
<p align="center"><b>5.1</b></p> <ul style="list-style-type: none"> <li>- Unit operates with a cooling and continuous fan demand.</li> <li>- Combustion air inducer energizes with Heating demand.</li> <li>- Ignitor is energized but unit fails to light.</li> </ul> <p>LED#1-Alternating Slow Flash LED#2-Alternating Slow Flash</p>	<p align="center"><b>5.1.1</b></p> <p>Check that gas is being supplied to the unit.</p>	<p><b>ACTION 1</b> - Check line pressure at the gas valve. Pressure should not exceed 13" WC for both natural and propane. Line pressure should read a minimum 4.5" WC for natural and 8.0"WC for propane.</p>
	<p align="center"><b>5.1.2</b></p> <p>Miswiring of gas valve or loose connections at multi-pin control amp plugs or valve.</p>	<p><b>ACTION 1</b> - Check for correct wiring and loose connections. Correct wiring and/or replace any loose connections.</p>
	<p align="center"><b>5.1.3</b></p> <p>Defective gas valve or ignition control.</p>	<p><b>ACTION 1</b> - Check that 24V is supplied to the gas valve approximately 35 seconds after heat demand is initiated. <b>ACTION 2</b> - Replace the valve if 24V is supplied but valve does not open. <b>ACTION 3</b> - Replace the control board if 24V is not supplied to valve.</p>

**PROBLEM 6: BURNERS LIGHT WITH A HEATING DEMAND BUT UNIT SHUTS DOWN PREMATURELY**

Condition	Possible Cause	Corrective Action/Comments
<p align="center"><b>6.1</b></p> <ul style="list-style-type: none"> <li>- Burners fire with a heating demand.</li> <li>- Burners light but unit shuts off prior to satisfying T-stat demand.</li> <li>- Diagnostic lights flash the pressure switch code.</li> </ul> <p>LED#1-Off LED#2-Slow Flash</p>	<p align="center"><b>6.1.1</b></p> <p>Low pressure differential at the prove switch.</p>	<p><b>ACTION 1</b> - Check for restricted exhaust vent. Remove all blockage. <b>ACTION 2:</b> Check for proper vent sizing. See installation instructions.</p>
	<p align="center"><b>6.2.1</b></p> <p>Sensor or sense wire is improperly installed.</p>	<p><b>ACTION 1</b> - Check that sensor is properly located and that the sense wire is properly attached to both the sensor and the control.</p>
	<p align="center"><b>6.2.2</b></p> <p>Sensor or sense wire is broken.</p>	<p><b>ACTION 1</b> - Check for a broken sensor. <b>ACTION 2</b> - Test continuity across the sense wire. If wire or sensor are damaged replace the component.</p>
	<p align="center"><b>6.2.3</b></p> <p>Sensor or sensor wire is grounded to the unit.</p>	<p><b>ACTION 1</b> - Check for resistance between the sensor rod and the unit ground. <b>ACTION 2</b> - Check for resistance between the sensor wire and the unit ground. <b>ACTION 3</b> - Correct any shorts found in circuit.</p>
<p align="center"><b>6.2</b></p> <ul style="list-style-type: none"> <li>- Combustion air inducer energizes with a heating demand.</li> <li>- Burners light but fail to stay lit.</li> <li>- After 5 tries the control diagnostics flash the watchdog burners failed to ignite code.</li> </ul> <p>LED#1-Alternating Slow Flash LED#2-Alternating Slow Flash</p>	<p align="center"><b>6.2.4</b></p> <p>Control does not sense flame.</p>	<p><b>ACTION 1</b> - Check the microamp signal from the burner flame. If the microamp signal is below normal microamps, check the sense rod for proper location or contamination. <b>ACTION 2</b> - Replace, clean, or relocate flame sense rod. If rod is to be cleaned, use steel wool or replace sensor. <b>DO NOT CLEAN ROD WITH SAND PAPER. SAND PAPER WILL CONTRIBUTE TO THE CONTAMINATION PROBLEM. NOTE:</b> Do not attempt to bend sense rod. <b>ACTION 3</b> - Check that there is proper ground to burner box. Repair as necessary.</p>

**PROBLEM 6: BURNERS LIGHT WITH HEATING DEMAND BUT UNIT SHUTS DOWN  
PREMATURELY (CONT.)**

Condition	Possible Cause	Corrective Action/Comments
<p align="center"><b>6.3</b></p> <ul style="list-style-type: none"> <li>- Combustion air inducer energizes with a heating demand.</li> <li>- Burners light.</li> <li>- Roll-out switch trips during the heating demand.</li> <li>- Diagnostic lights flash roll-out failure.</li> </ul> <p>LED#1-On LED#2-Slow Flash</p>	<p align="center"><b>6.3.1</b></p> <p align="center">Unit is firing above 100% of the nameplate input.</p>	<p><b>ACTION 1</b> - Check that the manifold pressure matches value listed on nameplate. See installation instructions for proper procedure.</p> <p><b>ACTION 2</b> - Verify that the installed orifice size match the size listed on the nameplate or installation instructions.</p> <p><b>ACTION 3</b> - Check the input rate to verify rate matches value listed on nameplate.</p>
	<p align="center"><b>6.3.2</b></p> <p align="center">Gas orifices leak at the manifold-connection.</p>	<p><b>ACTION 1</b> - Tighten orifice until leak is sealed. <b>NOTE:</b> Be careful not to strip orifice threads.</p> <p><b>ACTION 2</b> - Check for gas leakage at the threaded orifice connection. Use approved method for leak detection (see unit instructions).</p>
	<p align="center"><b>6.3.3</b></p> <p align="center">Insufficient flow through the heat exchanger caused by a sooted or restricted heat exchanger.</p>	<p><b>ACTION 1</b> - Check for sooting deposits or other restrictions in the heat exchanger assembly. Clean assembly as outlined in instruction manual.</p> <p><b>ACTION 2</b> - Check for proper combustion. See IV-Heating System Service Checks section G-.</p>
	<p align="center"><b>6.3.4</b></p> <p align="center">Burners are not properly located in the burner box.</p>	<p><b>ACTION 1</b> - Check that the burners are firing into the center of the heat exchanger openings. Correct the location of the burners if necessary.</p>
<p align="center"><b>6.4</b></p> <ul style="list-style-type: none"> <li>- Combustion air inducer energizes with a heating demand.</li> <li>- Burners light roughly and the unit fails to stay lit.</li> <li>- Diagnostic lights flash watchguard flame failure.</li> </ul> <p>LED#1-Alternating Slow Flash LED#2-Alternating Slow Flash</p>	<p align="center"><b>6.4.1</b></p> <p align="center">Poor Venting</p>	<p><b>ACTION 1</b> - Check vent pipe and remove any obstructions</p> <p><b>ACTION 2</b> - Check for correct exhaust vent installation. See instructions</p>
	<p align="center"><b>6.4.2</b></p> <p align="center">Improper burner cross-overs</p>	<p><b>ACTION 1</b> - Remove burner and inspect the cross-overs for burrs, or any restriction or if crossover is warped. Remove restriction or replace burners.</p>
	<p align="center"><b>6.4.3</b></p> <p align="center">Burrs in gas orifices</p>	<p><b>ACTION 1</b> - Remove gas orifices and inspect. Remove any burrs that are present or replace orifice.</p>

**PROBLEM 6: BURNERS LIGHT WITH HEATING DEMAND BUT UNIT SHUTS DOWN PREMATURELY (CONT.)**

<p align="center"><b>6.5</b></p> <ul style="list-style-type: none"> <li>- Combustion air inducer energizes with a heating demand.</li> <li>- Burners light.</li> <li>- Diagnostic lights flash watch guard flame failure.</li> <li>- NOTE" Unit might go into 60 minute Watchguard mode depending on intermittent nature of sensor signal.</li> </ul> <p>LED#1-Alternating Slow Flash LED#2-Alternating Slow Flash</p>	<p align="center"><b>6.5.1</b></p> <p>Loose sensor wire connection causes intermittent loss of flame signal.</p>	<p><b>ACTION 1</b> - Check that the sensor is properly located.</p> <p><b>ACTION 2</b> - Check that the sense wire is properly attached to both the sensor and the control. Pay extra attention to the pin connectors.</p>
	<p align="center"><b>6.5.2</b></p> <p>Poor ground to burner box</p>	<p><b>ACTION 1</b> - Check for proper ground and repair as necessary.</p>

**PROBLEM 7: CONTROL SIGNALS LOW FLAME SENSE DURING HEATING MODE**

Condition	Possible Cause	Corrective Action/Comments
<p align="center"><b>7.0</b></p> <ul style="list-style-type: none"> <li>- Unit operates correctly but the diagnostic lights flash low flame sense code.</li> </ul> <p>LED#1-Slow Flash LED#2-Fast Flash</p>	<p align="center"><b>7.1.1</b></p> <p>Sense rod is improperly located on the burner.</p>	<p><b>ACTION 1</b> - Check the sense rod for proper location on the burner. Properly locate the sense rod or replace if rod cannot be located correctly.</p>
	<p align="center"><b>7.1.2</b></p> <p>Sense rod is contaminated.</p>	<p><b>ACTION 1</b> - Check sense rod for contamination or coated surface. Clean the sense rod with steel wool or replace sensor. DO NOT USE SAND PAPER TO CLEAN ROD. SAND PAPER WILL CONTRIBUTE TO THE CONTAMINATION PROBLEM.</p>

**PROBLEM 8: INDOOR BLOWER FAILS TO OPERATE IN COOLING, HEATING, OR CONTINUOUS FAN MODE**

Condition	Possible Cause	Corrective Action/Comments
<p align="center"><b>8.0</b></p> <ul style="list-style-type: none"> <li>- Indoor blower fails to operate in continuous fan, cooling, or heating mode.</li> </ul>	<p align="center"><b>8.1.1</b></p> <p>Miswiring of furnace or improper connections at control or indoor blower motor.</p>	<p><b>ACTION 1</b> - Correct wiring and/or replace any loose connections. Check for correct wiring and loose connections.</p>
	<p align="center"><b>8.1.2</b></p> <p>120V is not being supplied to the indoor air blower or blower motor failure.</p>	<p><b>ACTION 1</b> - Check for 120V at the various calls for indoor blower by energizing "Y", "G", and "W" individually on the low voltage terminal strip. Note that when "W" is energized, the blower is delayed 45 seconds. If there is 120V to each motor tap but the blower does not operate, replace the motor.</p>
	<p align="center"><b>8.1.3</b></p> <p>Defective control board</p>	<p><b>ACTION 1</b> - If there is not 120V when "Y", "G", or "W" is energized, replace the control.</p>
	<p align="center"><b>8.1.4</b></p> <p>Defective run capacitor</p>	<p><b>ACTION 1</b> - Replace capacitor</p>

**PROBLEM 9: RF STATIC DURING TIME FOR IGNITION**

Condition	Possible Cause	Corrective Action/Comments
<p align="center"><b>9.0</b></p> <ul style="list-style-type: none"> <li>- AM radio interference.</li> </ul>	<p align="center"><b>9.1.2</b></p> <p>Ignitor operation</p>	<p><b>ACTION 1</b> - Call Technical Support, Dallas.</p>

## B-INDOOR BLOWER CONTROL MODULE

### PROBLEM

Indoor blower motor does not operate with heating, cooling or continuous fan demand.

#### CHECK WIRING

- Ensure that 6-pin connector is securely plugged into blower control module.
- Ensure that 3-pin motor connector is securely connected.
- Check power supply wiring to blower control module from 120HOT and neutral terminals on SureLight® control board.
- Ensure that leads from 6-pin connector are securely connected to the SureLight® control board.
- Make sure blower access panel is replaced properly to close door interlock switch and energize SureLight control board.
- Check for proper demand from thermostat.

Is motor operating properly?

YES

Recheck all wiring connections.

NO

#### CHECK SURELIGHT® OPERATION

- Ensure that 3-pin motor connector is securely connected.
- Connect lead from ACB Cool to 120HOT terminal.
- Make sure blower access panel is replaced properly to close door interlock switch and energize SureLight® control board.
- Repeat with ACB Heat and ACB Low leads.

Does motor operate when power is applied to SureLight® control board?

YES

Problem is with SureLight® control board. ACB terminals are not energized. Follow SureLight® diagnostic procedures.

NO

#### CHECK BLOWER MOTOR

- Disconnect 6-pin connector from blower control module. Also, disconnect 3-pin motor connector.
- Disconnect wires from HOT and Neutral terminals on blower control module. Connect these wires directly to the blower motor (may require splicing).
- Make sure blower access panel is replaced properly to close door interlock switch and energize SureLight® control board.

Does motor operate when power is applied to unit?

NO

Blower motor is not working properly. Follow motor diagnostic procedures and replace blower motor, if necessary.

YES

Blower control module is not working properly. Replace blower control module.

**PROBLEM**  
Indoor blower motor does not operate at the correct speed.

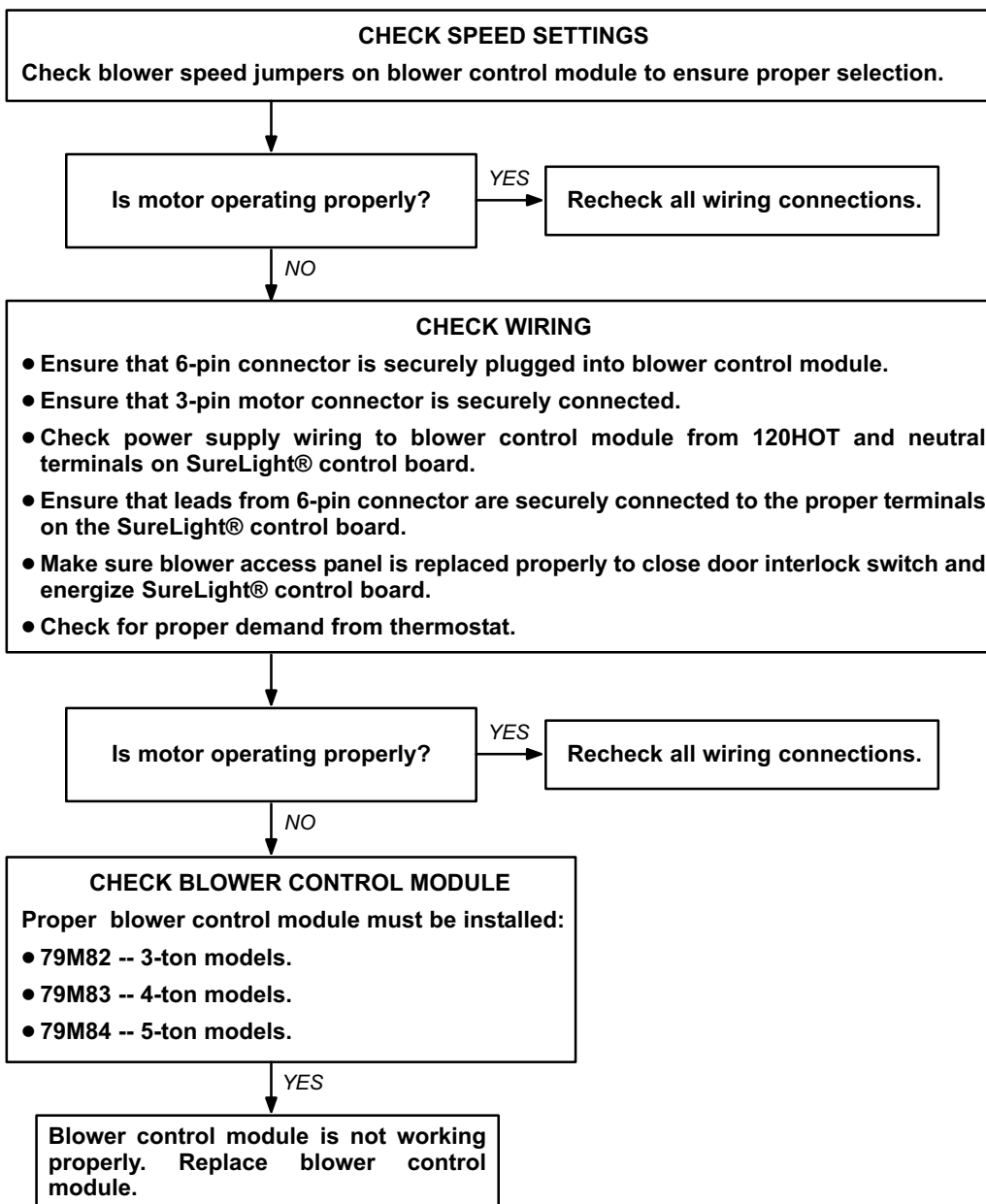

**⚠ CAUTION**

The blower control module and single-tap motor used in G50UH units are designed specifically for use with one another. If a PSC blower motor is used to provide emergency operation, the PSC motor must be connected to the SureLight® control board, rather than the blower control module. If the SureLight® control board is used to control blower operation in an emergency situation, the single-tap motor must be temporarily replaced using a PSC motor. If these instructions are ignored, control board or blower motor failure may result, causing a potentially hazardous condition.