

## G25MV SERIES UNITS

G25MV series units are mid-efficiency gas furnaces manufactured with tubular steel heat exchangers formed of aluminized steel. G25MV units are available in heating capacities of 60,000 to 120,000 Btuh (17.6 to 35.2 kW) and cooling applications from 1.5 through 5 tons (3.5 through 17.6 kW). Refer to Engineering Handbook for proper sizing.

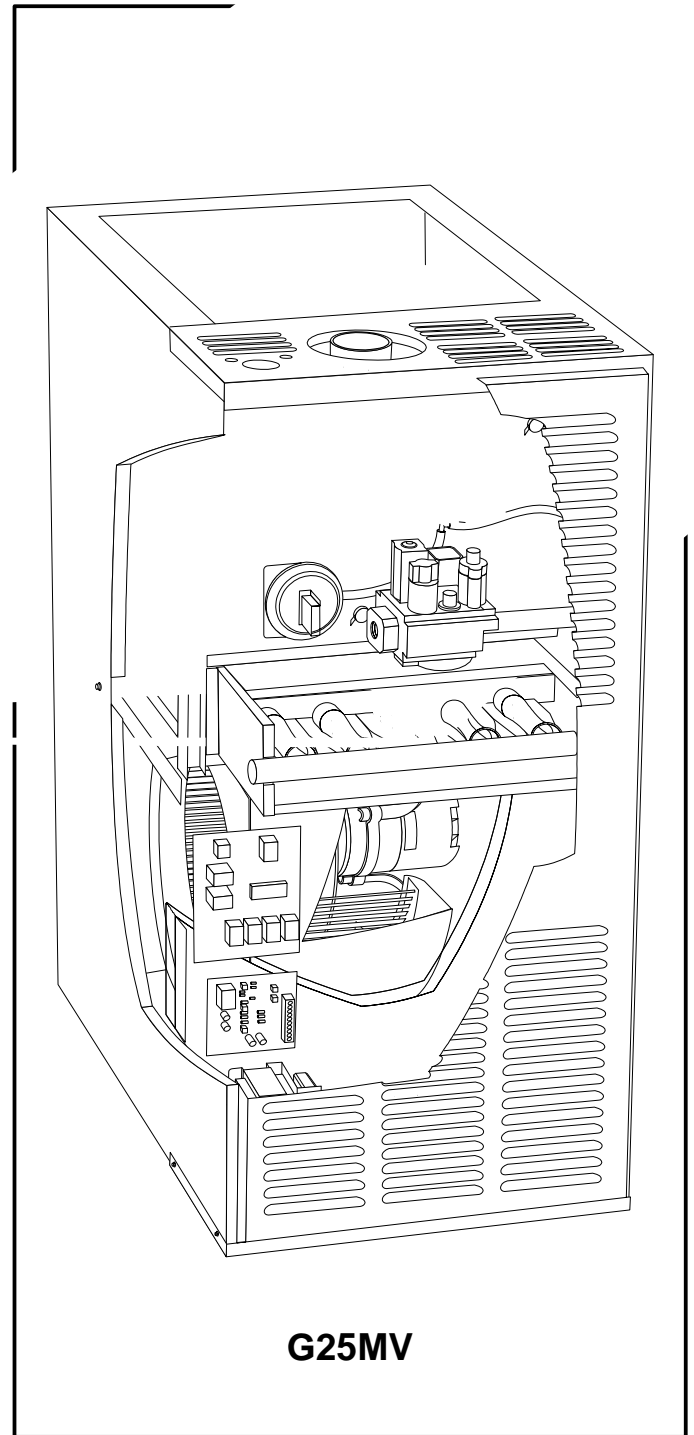
Units are factory equipped for use with natural gas. G25MV units use a hot surface ignition system. G25MV units meet the California Nitrogen Standards and California Seasonal Energy Efficiency Ratings. All units use a two stage burner and a two stage induced draft blower. The blower is redundant to assure safe operation. A.G.A. or C.G.A.

All G25MV units are available in a standard or a special size range.

Units may be installed in upflow, downflow or horizontal position. The heat exchanger is designed for upright or horizontal use only. When the unit is installed in the downflow position, the heat exchanger is field removed and reinstalled so it is upright when the cabinet is inverted. No field conversion is required when the unit is installed in the horizontal position.

The heat exchanger, burners and manifold assembly can easily be removed for inspection and service by simply disconnecting gas, unplugging wiring harnesses and removing four screws holding the heat exchanger in place. The heat exchanger slides out of the cabinet.

Information contained in this manual is intended for use by Lennox service technicians only. All specifications are subject to change. Procedures outlined in this manual are presented as a recommendation only and do not supersede or replace local or state codes.



## SPECIFICATIONS

Model No.	G25MV3-60	G25MV3-75	G25MV5-100	G25MV5-120
Input Btuh (kW) high fire	60,000 (17.6)	75,000 (22.0)	100,000 (29.3)	120,000 (35.2)
Output Btuh (kW) high fire	48,000 (14.1)	60,000 (17.6)	80,000 (23.4)	96,000 (28.1)
●A.F.U.E.	80.0%	80.0%	80.0%	80.0%
Input Btuh (kW) low fire	40,800 (12.0)	51,000 (15.0)	68,000 (20.0)	81,600 (24.0)
†Flue size connection diameter — in. (mm) round	3 (76)	4 (102)	4 (102)	4 (102)
Temperature rise range — °F (°C)	30 – 60 (17 – 33) low fire 40 – 70 (22 – 39) high fire			
High static certified by A.G.A./C.G.A. — in wg. (Pa)	.80 (200)	.80 (200)	.80 (200)	.80 (200)
Gas Piping Size I.P.S. Natural gas only	1/2 (13)	1/2 (13)	1/2 (13)	1/2 (13)
Blower wheel nominal diameter x width	in.	10 x 7	10 x 7	12 x 9
	mm	254 x 178	254 x 178	305 x 229
Blower motor output — hp (W)	1/2 (373)	1/2 (373)	1 (746)	1 (746)
Unit minimum circuit ampacity (amps)	12.2		18.2	
Unit maximum fuse or circuit breaker size	15.0		20.0	
Electrical characteristics	120 volts — 60 hertz — 1 phase			
Nominal cooling that can be added	Tons	2, 2-1/2 or 3	2, 2-1/2 or 3	3-1/2, 4 or 5
	kW	7.0, 8.8 or 10.6	7.0, 8.8 or 10.6	12.3, 14.1 or 17.6
※Up-flow/Horizontal Filter Kit (furnished) — filter size	(1) 16 x 20 x 1 (406 x 508 x 25)		(1) 20 x 20 x 1 (508 x 508 x 25)	
Shipping weight — lbs. (kg) 1 package	135 (61)	135 (61)	175 (79)	175 (79)
▼ <b>Optional Accessories (Must Be Ordered Extra)</b> ▼				
◆Down-flow Filter Kit	Catalog No.	LB-69843A (32J01) — 3 lbs. (1 kg)		
	No. & Size of Filters — in. (mm)	(2) 16 x 20 x 1 (406 x 508 x 25)		
Down-flow Combustible Floor Base	LB-79239A (67J91) — 10 lbs. (4 kg)		LB-79239B (67J92) — 10 lbs. (4 kg)	
Hanging Bracket Kit	LB-69957 (46J66) — 15 lbs. (7 kg)			

●Annual Fuel Utilization Efficiency based on U.S. DOE test procedures and according to FTC labeling regulations. Isolated combustion system rating for non-weatherized furnaces.

◆Filters are not furnished with kit and must be ordered extra. ※Polyurethane frame type filter is furnished with kit.

† 2 in. x 3 in. (51 mm x 76 mm) flue adaptor furnished with -60 input furnaces for connection to furnace induced draft blower.

‡ 2 in. x 4 in. (51 mm x 102 mm) flue adaptor furnished with -75, -100 & -120 input furnaces for connection to furnace induced draft blower.

## BLOWER PERFORMANCE DATA

**G25MV3-60 & G25MV3-75 BLOWER PERFORMANCE**  
**0 through 0.80 in. w.g. (0 Through 200 Pa) External Static Pressure Range**  
**VSP2-1 Blower Control — Factory Settings**  
**G25MV3-60 = Low Speed — 1 / High Speed — 4 / Heat Speed — 1**  
**G25MV3-75 = Low Speed — 3 / High Speed — 4 / Heat Speed — 2**

"ADJUST" Jumper Setting	VSP2-1 Jumper Speed Positions																							
	"LOW" Speed (Cool Or Continuous Fan)								"HIGH" Speed (Cool)								"HEAT" Speed							
	1		2		3		4		1		2		3		4		1		2		3		4	
	cfm	L/s	cfm	L/s	cfm	L/s	cfm	L/s	cfm	L/s	cfm	L/s	cfm	L/s	cfm	L/s	cfm	L/s	cfm	L/s	cfm	L/s	cfm	L/s
NORM	640	300	740	350	890	420	1030	485	1060	500	1100	520	1260	595	1340	630	850	400	1050	495	1280	605	1370	645
—	600	285	680	320	810	380	920	435	930	440	1020	480	1130	535	1200	565	780	370	945	445	1160	545	1240	585

NOTE — The effect of static pressure and filter resistance is included in the air volumes listed.

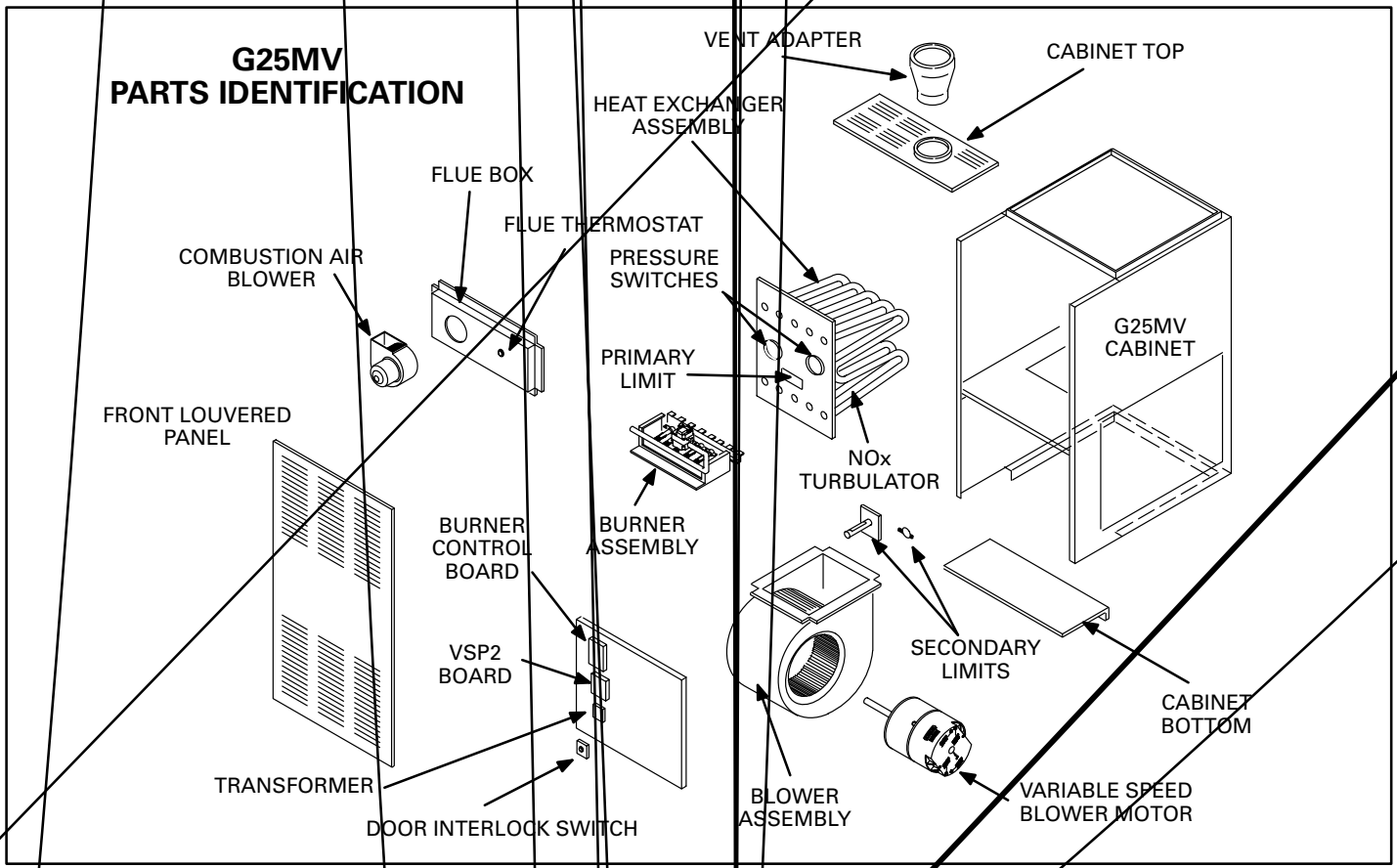
**G25MV5-100 & G25MV5-120 BLOWER PERFORMANCE**  
**0 through 0.80 in. w.g. (0 Through 200 Pa) External Static Pressure Range**  
**VSP2-1 Blower Control — Factory Settings**  
**G25MV5-100 = Low Speed — 2 / High Speed — 4 / Heat Speed — 1**  
**G25MV5-120 = Low Speed — 3 / High Speed — 4 / Heat Speed — 2**

"ADJUST" Jumper Setting	VSP2-1 Jumper Speed Positions																							
	"LOW" Speed (Cool Or Continuous Fan)								"HIGH" Speed (Cool)								"HEAT" Speed							
	1		2		3		4		1		2		3		4		1		2		3		4	
	cfm	L/s	cfm	L/s	cfm	L/s	cfm	L/s	cfm	L/s	cfm	L/s	cfm	L/s	cfm	L/s	cfm	L/s	cfm	L/s	cfm	L/s	cfm	L/s
NORM	690	325	1170	550	1440	680	1480	700	1620	765	1820	860	2000	945	2100	990	1420	970	1720	810	2030	960	2150	1015
—	580	275	1050	495	1280	605	1360	640	1350	635	1550	730	1700	800	1800	850	1280	605	1550	730	1800	850	1900	895

NOTE — The effect of static pressure and filter resistance is included in the air volumes listed.

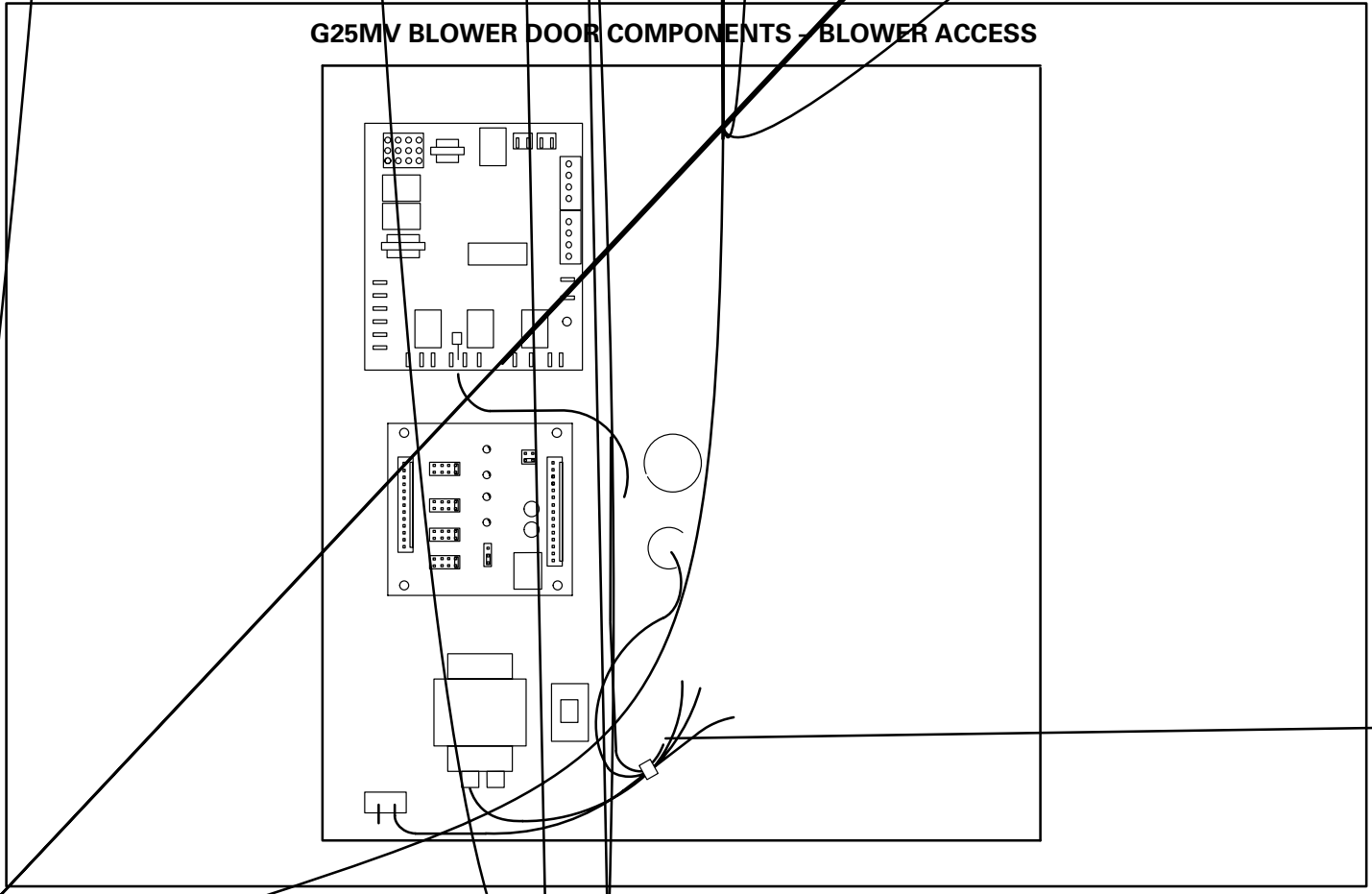
NOTE — Do not adjust jumper settings (CFM) below tap# 2 "NORMAL" for both "LOW" speed and "HEAT" speed for the G25MV5-120 units only.

# G25MV PARTS IDENTIFICATION



**FIGURE 1**

# G25MV BLOWER DOOR COMPONENTS - BLOWER ACCESS



**FIGURE 2**

## **I-UNIT COMPONENTS (Figure 1)**

G25MV unit components are shown in figure 1. The blower controls, gas valve and burners can be accessed by removing the front access panel. A separate blower access door is located behind the front access panel. Electrical control components are mounted to the blower access door. Units are factory equipped with bottom return air panels

### **A-Blower Door Components (Figure 2)**

Electrical burner control and blower control components are located on the outside surface of the blower access door. Jackplugs allow the blower door to be easily removed for blower service.

Located on the blower door are the unit transformer (T1), burner control (A3), VSP2 blower control board (A24), and door interlock switch (S51).

#### **1- Control Transformer (T1)**

A transformer located on the blower door provides power to the low voltage section of the unit. Transformers on all models are rated 50VA with a 120V primary and a 24V secondary. The transformer is protected by a 3.0 amp circuit breaker.

#### **2-Door Interlock Switch (S51)**

A door interlock switch rated 16A at 125VAC is located on the blower access door. The switch is wired in series with line voltage. When the blower door is removed the unit will shut down.

#### **3- Burner Control (A3)**

All G25MV units utilize a burner control manufactured by RAM Electronics Corporation. The "RAM" board is a printed circuit board which controls the gas valve, combustion air blower and ignition. It also monitors the flame, limit and gas valve operation. The board utilizes both 120 and 24VAC. See figure 3. The board is equipped with a diagnostic LED for use when troubleshooting the unit.

When the furnace is idle (blower off and no heating or cooling demand), the diagnostic LED flashes at a slow steady rate. On a call for heat, the diagnostic LED begins flashing at a fast rate and the combustion air blower is energized. The LED flashes different codes to indicate problem conditions. The diagnostic LED lights red (not flashing) to indicate control board failure. Table 1 shows how to interpret the other LED modes.

#### ***Pre-Purge***

On a call for heat, the combustion air blower begins operating. If the combustion air prove switch closes, the combustion air blower continues to operate for 30 seconds (pre-purge) before allowing ignition. Pre-purge allows the heat exchanger to be cleared of combustion products and to introduce fresh air for combustion. If the combustion air prove switch does not close, the combustion air blower continues to run indefinitely (until the prove switch closes).

#### ***Post-Purge***

After a demand, the combustion air blower continues to operate for 5 seconds (post-purge) before stopping. Post-purge allows the heat exchanger to be cleared of combustion products.

#### ***Ignition Control***

The ignition control is a hot surface ignition control module integral to the burner control. See table 2 and figure 3. When there is a call for heat, the control delays ignition until combustion air blower operation has been proved and pre-purge period has elapsed. It then energizes a hot surface for 35 seconds. At the end of the 35 seconds the main gas valve opens on high fire. Trial for ignition lasts for 7 seconds. At the same time, the control begins monitoring the flame.

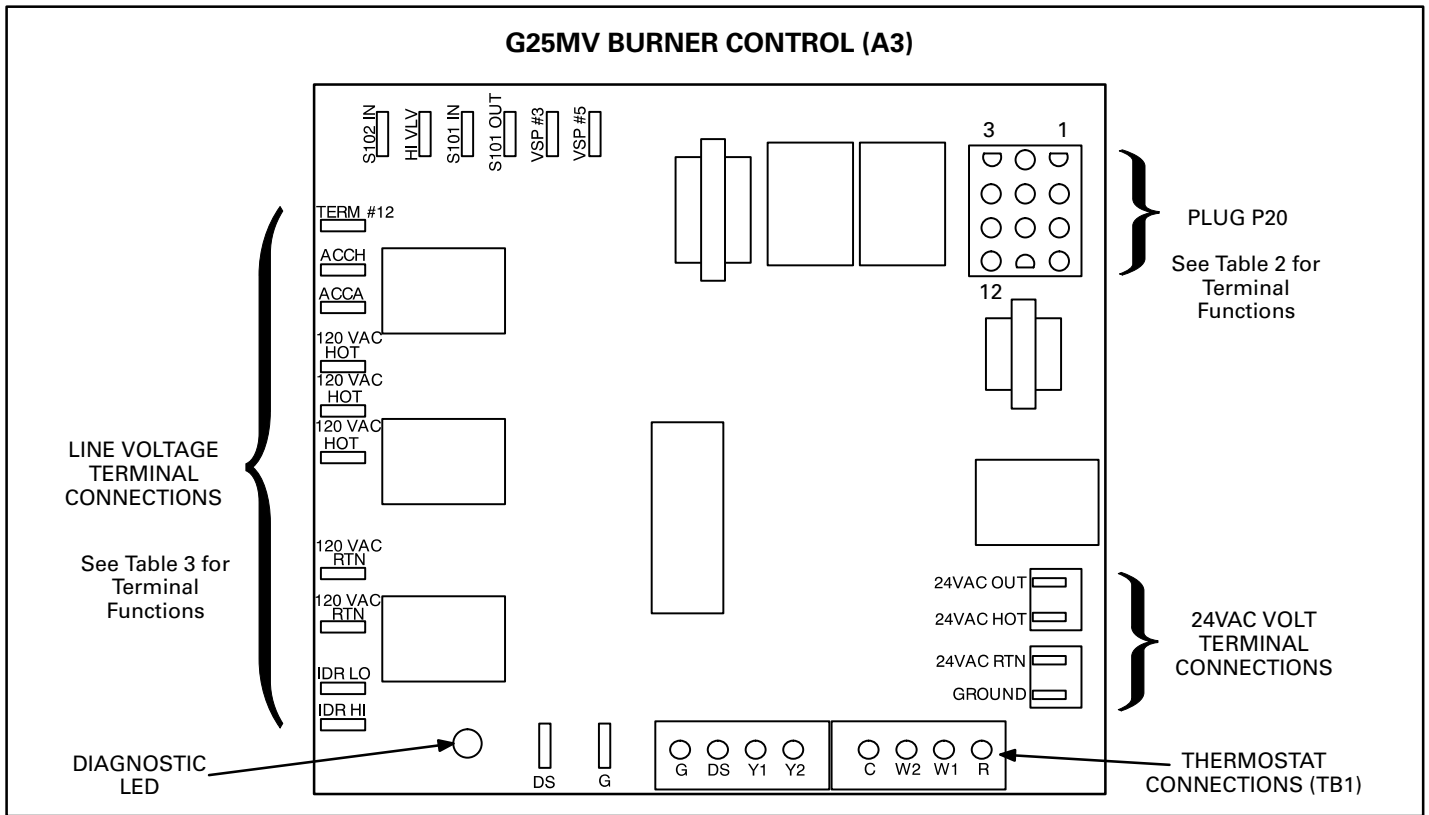


FIGURE 3

**Diagnostic LED**

The burner control is equipped with a diagnostic LED used for troubleshooting the unit and the control. LED functions are shown in table 1.

TABLE 1

Burner Control A3 Diagnostic LED		
LED State	Meaning	Remedy
Steady On	Control Failure	Replace Control
Slow Flash	Normal Operation and No Call For Heat	----
Fast Flash	Normal Operation with Call For Heat	----
Two Flashes	Control Lockout	Failed to Sense or Sustain Flame. Check Gas Valve, Burners, Hot Surface Ignitor and Wire, Flame Sensor. Replace Control If All OK.
Three Flashes	Pressure Switch Open	Failed to Prove Combustion Blower Operation or Blocked Vent. Repair or Replace as Necessary.
Four Flashes	Open Limit	Check Primary Limit, Rollout Switches and Secondary Limits. Find source of Over temperature. If all OK, Reset or Replace Limits as Necessary.
Five Flashes	Flame Sensed and Gas Valve Not Energized.	Check Gas Valve. If OK, Check Flame Sensor.
Six Flashes	Failed Hot Surface Ignitor	Check Hot Surface Ignitor Voltage. If OK, Replace Ignitor

**⚠ DANGER**

Shock hazard.

Disconnect power before servicing. Control is not field repairable. If control is inoperable, simply replace entire control.

Can cause injury or death. Unsafe operation will result if repair is attempted.

TABLE 2

BURNER CONTROL JACK/PLUG 20 TERMINAL DESIGNATIONS	
Pin #	Function
1	High Fire Pressure Switch Output
2	Low Valve Output
3	Low Fire Pressure Switch Output
4	Blank
5	Limits Input
6	High Limit Input
7	Flame Sensor
8	Limits Output
9	Valve Return
10	Blank
11	Ignitor Return
12	Ignitor Output

TABLE 3

BURNER CONTROL A3 TERMINAL DESIGNATIONS		
Terminal	Type	Function
24VAC OUT	1/4" Spade	24VAC Out To VSP2
24VAC HOT	1/4" Spade	24VAC In From Transformer
24VAC RTN	1/4" Spade	24VAC In From VSP2
GROUND	1/4" Spade	To Cabinet Ground
G	Screw Strip	Blower Demand
DS	Screw Strip	Input Harmony Zone Control
Y1	Screw Strip	First Stage Cooling Demand
Y2	Screw Strip	Second Stage Cooling Demand
C	Screw Strip	24VAC Common
W2	Screw Strip	Second Stage Heating Demand
W1	Screw Strip	First Stage Heating Demand
R	Screw Strip	24VAC to Thermostat
G	1/4" Spade	Blower Demand to VSP2
DS	1/4" Spade	Harmony Zone To VSP2
IDR HI	1/4" Spade	120VAC Out To High Speed Combustion Air Blower (B6)
IDR LO	1/4" Spade	120VAC Out To Lo Speed Combustion Air Blower (B6)
120VAC RTN	1/4" Spade	120VAC Return From Combustion Air Blower (B6)
120VAC RTN	1/4" Spade	120VAC Return From (T1)
120VAC HOT	1/4" Spade	120VAC In From Door Interlock Switch (S51)
120VAC HOT	1/4" Spade	120VAC Output To Control Transformer (T1)
120VAC HOT	1/4" Spade	120VAC To Blower Motor (B3)
ACCA	1/4" Spade	Accessory Cooling Terminal
ACCH	1/4" Spade	Accessory Heating Terminal
TERM #12	1/4" Spade	24VAC Accessory Input
S102 IN	1/4" Spade	24VAC In From High Fire Pressure Switch
HI VLV	1/4" Spade	24VAC Out To Gas Valve (GV1)
S101 IN	1/4" Spade	24VAC In From Flue Thermostat
S101 OUT	1/4" Spade	24VAC Out To Flue Thermostat
VSP #3	1/4" Spade	Second Stage Heat Output-VSP2
VSP #5	1/4" Spade	Limit Output To VSP2

### 4-VSP2 Blower Control Board (A24)

G25MV units are equipped with a variable speed motor that is capable of maintaining a specified CFM throughout the external static range. The unit uses the VSP2-1 variable speed control board, located on the blower access door, which controls the blower speed and provides diagnostic LEDs. The control has both a non-adjustable, factory preset "ON" fan timing delay and an adjustable "OFF" fan timing delay (see figure 6).

The VSP2-1 also senses limit trip condition and turns on the blower. The G25MV limit switch is located in the middle of the vestibule wall. When excess heat is sensed in the heat exchanger, the limit switch will open and interrupt the current to the gas valve, while at the same time the VSP2-1 energizes the blower on heating speed. The limit automatically resets when the unit temperature returns to normal and the blower is de-energized.

Diagnostic LEDs located on the VSP2-1 control board are provided to aid in identifying the unit's mode of operation. Certain scenarios will arise depending on the jumper positions. Refer to figure 4 for identification.

**⚠ IMPORTANT**

**24 VAC half wave rectified (DC pulse), when measured with a meter, may appear as a lower or higher voltage depending on the make of the meter. Rather than attempting to measure the output voltage of A24, see G25MV BLOWER & VSP2 BLOWER CONTROL BOARD TROUBLESHOOTING FLOW CHART in the TROUBLESHOOTING section of this manual.**

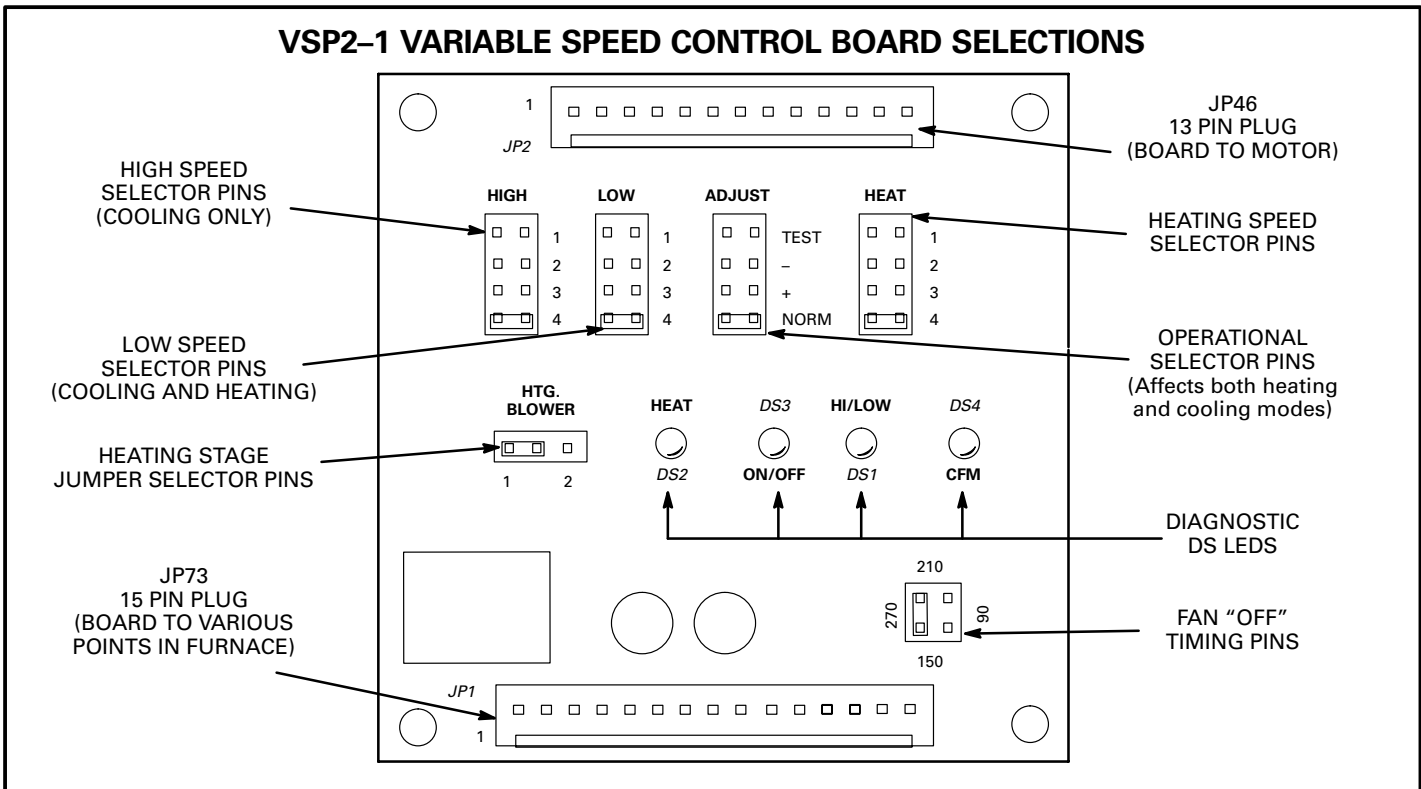


FIGURE 4

## Diagnostic LED Lights

### a-DS3 "ON/OFF"

**ON/OFF-DS3** indicates there is a demand for the blower motor to run. When the **ON/OFF LED-DS3** is lit, a demand is being sent to the motor. In heating mode only, there is a 45 second fan "ON" delay in energizing **ON/OFF LED-DS3**. The light will not go off until adjustable fan "OFF" delay has expired.

If **ON/OFF LED-DS3** is on and both **HIGH/LOW LED-DS1** & **HEAT LED-DS2** are off, the motor will operate in low speed.

### b-DS2 "HEAT"

If **HEAT LED-DS2** is on, the blower is running in the heat speed according to the "HEAT" jumper setting. The **HEAT LED-DS2** comes on instantaneous and switches off when the call for heat is satisfied.

*NOTE-When the blower is in "OFF" delay mode, the motor runs at low speed, therefore the HEAT LED-DS2 is off. It switches off when the call for heat is satisfied.*

### c-DS1 "HI/LOW"

**HIGH/LOW LED-DS1** indicates whether the blower is operating in high or low speed. When the light is off, the blower is running in low speed according to the "LOW" jumper setting. When **HIGH/LOW LED-DS1** is on, the blower is operating in high speed according to the "HIGH" jumper setting.

### d-DS4 "CFM"

**CFM LED-DS4** indicates the CFM the unit is operating, according to the jumper settings. The light flashes once for approximately every 100 CFM. For example, if the unit is operating at 1000 CFM, **CFM LED-DS4** will flash 10 times. If the CFM is 2050, **CFM LED-DS4** will flash 20 full times plus one fast or half flash.

At times the light may appear to flicker or glow. This takes place when the control is communicating with the motor between cycles. This is normal operation.

The appropriate speed according to application and CFM need is selected by moving jumper pins.

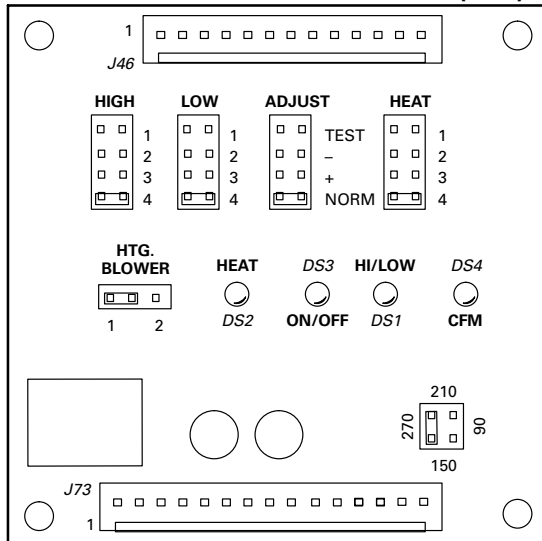
*NOTE-On Harmony II zoning applications in the heating mode, the highest speed obtainable is the same as the highest cooling speed selection. Also, the heating speed (heat jumper position) is only used when the primary limit has been tripped. In non-zoning applications, refer to the section on the VSP2-1 control.*

## Jumper Settings

### ▲ IMPORTANT

**Before changing jumper setting, make sure the motor has completely stopped. Any jumper setting change will not take place while the motor is running.**

## VSP2 BLOWER CONTROL BOARD (A24)



### J73

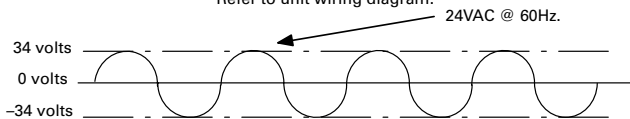
- PIN 1 - C - 24 VAC common.
- PIN 2 - G - Input signal from thermostat's fan signal.
- PIN 3 - W2 - Input signal for second stage heat from the thermostat.
- PIN 4 - DS - Input signal for the blower speed regulation.
- PIN 5 - Limit - Input signal from the external limit.
- PIN 6 - R - 24 VAC power to the thermostat.
- PIN 7 - C - 24 VAC common.
- PIN 8 - C - 24 VAC common.
- PIN 9 - Cl - Input signal from the fan limit control.
- PIN 10 - CO - Output signal to the burner control.
- PIN 11 - HT - Input signal from the fan limit control.
- PIN 12 - ACC - 24 VAC accessory output.
- PIN 13 - 24V - Input 24 VAC power for the VSP2-1.
- PIN 14 - 24V - Input 24 VAC power for the VSP2-1.
- PIN 15 - V - Input signal from the gas line.

### J46

- PIN 1 - Heat - Heat speed input signal to the ICM2 motor.
- PIN 2 - C - 24 VAC common.
- PIN 3 - C - 24 VAC common.
- PIN 4 - High Tap - High Speed programming input.
- PIN 5 - Low Tap - Low speed programming input.
- PIN 6 - On / Off - On / off output signal to the ICM2 motor.
- PIN 7 - Adjust Tap - ICM2 mode selection.
- PIN 8 - Hi / Low - Speed regulate input signal to the ICM2 motor.
- PIN 9 - Hi / Low - Speed regulate input signal to the ICM2 motor.
- PIN 10 - Ref. V - ICM2 reference voltage.
- PIN 11 - Heat Tap - Heating blower speed programming.
- PIN 12 - C - 24 VAC common.
- PIN 13 - cfm - Motor speed diagnostic signal.

## VOLTAGES INTO VSP2

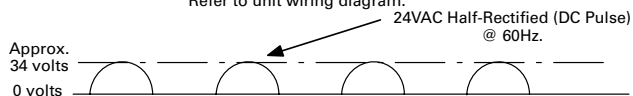
Voltage across J73 pins 13 to 1 and 6 to 1 is 24VAC as shown here. Refer to unit wiring diagram.



Voltage across J73 pins 4 to 1 is approximately 15-20VDC (straight voltage) if CCB is used. If Harmony is used a voltage of 0-25VDC should be present. If CCB or Harmony is not used, pin 4 to 1 voltage is 21VAC.

## VOLTAGES FROM VSP2 TO ELECTRONICALLY CONTROLLED BLOWER MOTOR

Voltage across J46 pins 6 to 3 and 1 to 3 is half-rectified AC as shown here. Refer to unit wiring diagram.



Voltage across J46 pins 8 and 9 to 3, is approximately 15-20VDC if CCB is used. If CCB or Harmony is not used, pins 8 and 9 to 3 voltage is approximately 21VAC. If Harmony is used a voltage of 0-25VDC should be present.

FIGURE 5

To change jumper positions, gently pull the jumper off the pins and place it on the desired set of pins. The following section outlines the different jumper selections available and conditions associated with each one. Refer to figure 4 for identification.

After the CFM for each application has been determined, the jumper settings must be adjusted to reflect those given in the tables on page 2. Using the tables, determine which row of CFM volumes most closely matches the desired CFM. Once a specific row has been chosen (NORMAL or –), CFM volumes from other rows cannot be used. Below are the descriptions of each of the jumper selections.

Refer to table 4 for factory settings. Refer to the tables on page 2 for the approximate air volume for each setting.

**TABLE 4  
VSP2-1 FACTORY SETTINGS**

MODEL NUMBER	HIGH	LOW	ADJUST	HEAT
G25MV3-60	4	1	NORM	1
G25MV3-75	4	3	NORM	2
G25MV5-100	4	2	NORM	1
G25MV5-120	4	3	NORM	2

**a–“ADJUST”**

The **ADJUST** pins allow the motor to run at normal speed or approximately 10% lower than normal speed. The tables on page 2 give two rows (NORMAL and –) with their respective CFM volumes. The + adjustment setting is not operable. Notice that the normal adjustment setting for heat speed position #3 is 2030 CFM (960 L/s). After the adjustment setting has been determined, chose the remaining speed jumper settings from those offered in the table.

The **TEST** pin is available to bypass the VSP2-1 control and run the motor at approximately 70% to test that the motor is operational. This is beneficial primarily in troubleshooting. G must be energized for motor to run.

**b–“HEATING BLOWER”**

For G25MV units, place the **HEATING BLOWER** jumper across the second and third pins (position #2).

When W1 is energized, the **LOW** jumper selections are activated. The **HEAT** jumper selections are activated when W2 is energized.

*NOTE—In Harmony II zoning applications, HEATING BLOWER jumper must be in position #2.*

**c–“HEAT”**

The **HEAT** jumper is used to set the blower speed to obtain the required CFM as outlined in HEAT SPEED section of the tables on page 2.

The **HEAT** jumper selections are activated with a call for second-stage heating (W2).

**▲ IMPORTANT**

**Before changing jumper setting, make sure the motor has completely stopped. Any jumper setting change will not take place while the motor is running.**

**d–“HIGH”**

The **HIGH** jumper is used to determine the CFM during cooling speed. These jumper selections are activated when G and DS terminals are energized.

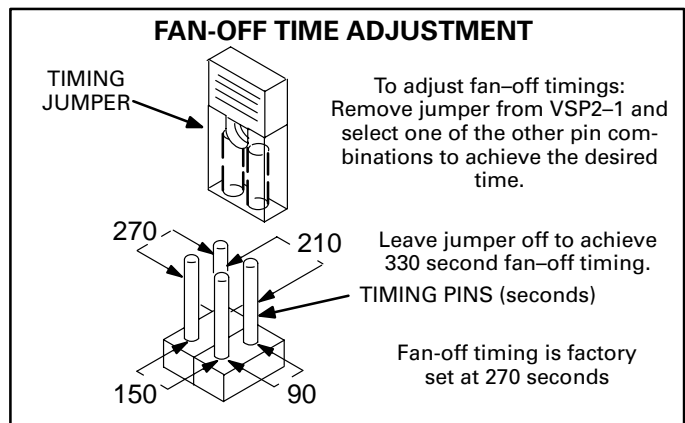
**e–“LOW”**

The **LOW** jumper is used to determine CFM during low speed cooling. These jumper selections are activated when G is energized. The **LOW** jumper may also be used for low speed heating. See the “HEAT” section for details.

**f–FAN “OFF”**

Fan “OFF” timings (time that the blower operates after the heat demand has been satisfied) are determined by the arrangement of a jumper on the VSP2-1 board. See figure 6. To adjust fan “OFF” timings, gently disconnect the jumper and reposition it across pins corresponding with the new timing. Fan “OFF” time is factory set at 270 seconds. The control has a non-adjustable, factory preset “on” fan timing (45 seconds).

**WARNING – MAKE SURE TO DISCONNECT POWER BEFORE CHANGING FAN “OFF” TIMINGS.**



**FIGURE 6**

*NOTE—If fan “OFF” time is too low, residual heat in heat exchanger may cause primary limit S10 to trip resulting in frequent cycling of blower. If this occurs, adjust blower to longer time setting.*

Table 5 outlines the operation of the variable speed motor in relation to specific modes of operation. Some information has been repeated from the previous section to provide an example. Refer to each diagnostic LED or jumper settings section for more information.

**TABLE 5  
VSP2-1 OPERATION**

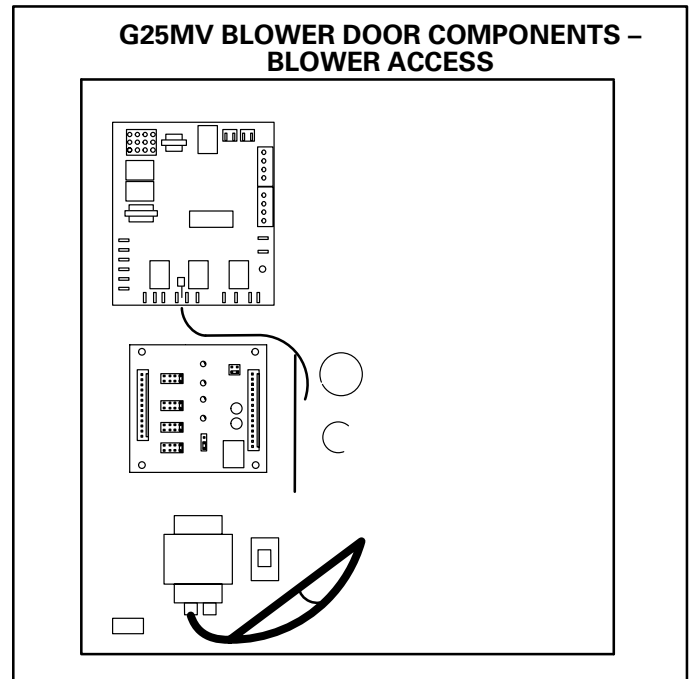
HEATING MODE		COOLING MODE	
UNITS WITH SINGLE-STAGE HEATING	UNITS WITH TWO-STAGE HEATING	UNITS WITH SINGLE-SPEED COMPRESSOR	UNITS WITH TWO-SPEED COMPRESSOR
<p align="center"><b>NON-ZONED APPLICATIONS</b></p> <p>When a single-stage thermostat is used and full heating input of the unit is required, jump terminals W1 and W2 on the burner control board.</p> <p>The <b>HEAT</b> LED-DS2 is lit when the thermostat calls for heat. The <b>ON/OFF</b> LED-DS3 is lit after 110 seconds (65 seconds pre-purge and 45 seconds fan "ON" time) from the time a call for heat is made. This indicates the blower is operating in heating speed.</p>	<p align="center"><b>NON-ZONED APPLICATIONS</b></p> <p>Using a two-stage thermostat with first-stage (W1) calling, the <b>ON/OFF</b> LED-DS3 is lit to indicate the blower is operating in low speed.</p> <p>When the <b>ON/OFF</b> LED-DS3 and <b>HEAT</b> LED-DS2 are lit, the blower is operating in heating speed and second-stage (W2) heating is calling.</p> <p><b>HEAT</b> LED-DS2 is lit with a call for heat from the thermostat. <b>ON/OFF</b> LED-DS3 is lit after 110 seconds from the time a call for heat is made.</p> <p><i>NOTE—In two-stage operation and when there is a call for first-stage only, the unit will always start on high heat (second-stage) and will automatically switch to first-stage operation after initial unit warm-up.</i></p>	<p align="center"><b>NON-ZONED APPLICATIONS</b></p> <p>The terminals "DS" and "Y" must be jumpered together. With a call for cooling, terminals G, Y and DS on the unit control board are energized from the thermostat. <b>HI/LOW</b> LED-DS1 and <b>ON/OFF</b> LED-DS3 are lit to indicate the blower is operating on high speed.</p> <p><i>NOTE—"Y" and "DS" must be jumpered for single-stage cooling, non-zoned applications.</i></p>	<p align="center"><b>NON-ZONED APPLICATIONS</b></p> <p>The <b>ON/OFF</b> LED-DS3 is lit to indicate the blower is operating in first stage cooling. This LED is energized on when a 24VAC thermostat demand is supplied to the control (terminal "G" on the control box terminal strip).</p> <p>In second stage, the <b>ON/OFF</b> LED-DS3 and <b>HI/LOW</b> LED-DS1 are lit to indicate the blower is operating on high speed (24VAC is supplied to the unit terminal strip "Y2" from "Y2" on the thermostat).</p> <p><i>NOTE—"Y2" must be jumpered to "DS" in two-speed, non-zoned applications.</i></p>
<p align="center"><b>HARMONY ZONED APPLICATIONS</b></p> <p>The blower speed is controlled by the PWM (pulse width modulation) signal sent from the control center of the zoning system to the terminal strip's "DS" terminal. <b>HI/LOW</b> LED-DS1 and <b>ON/OFF</b> LED-DS3 are lit to indicate the blower is operating.</p> <p><i>NOTE—In Harmony II zoning applications, HTG. BLOWER jumper must be in position #2.</i></p>	<p align="center"><b>HARMONY ZONED APPLICATIONS</b></p> <p>The blower speed is controlled by the PWM (pulse width modulation) signal sent from the control center of the zoning system to the terminal strip's "DS" terminal. <b>HI/LOW</b> LED-DS1 and <b>ON/OFF</b> LED-DS3 are lit to indicate the blower is operating.</p> <p><i>NOTE—In Harmony II zoning applications, HTG. BLOWER jumper must be in position #2.</i></p>	<p align="center"><b>HARMONY ZONED APPLICATIONS</b></p> <p>The blower speed is controlled by the PWM (pulse width modulation) signal sent from the control center of the zoning system to the terminal strip's "DS" terminal. <b>HI/LOW</b> LED-DS1 and <b>ON/OFF</b> LED-DS3 are lit to indicate the blower is operating.</p>	<p align="center"><b>HARMONY ZONED APPLICATIONS</b></p> <p>The blower speed is controlled by the PWM (pulse width modulation) signal sent from the control center of the zoning system to the terminal strip's "DS" terminal. <b>HI/LOW</b> LED-DS1 and <b>ON/OFF</b> LED-DS3 are lit to indicate the blower is operating.</p>

**NOTE: For zone applications with Harmony, remove wire from VSP #3 terminal on burner control board, insulate end and secure to prevent from shorting.**

### B-Blower Compartment (Figure 8)

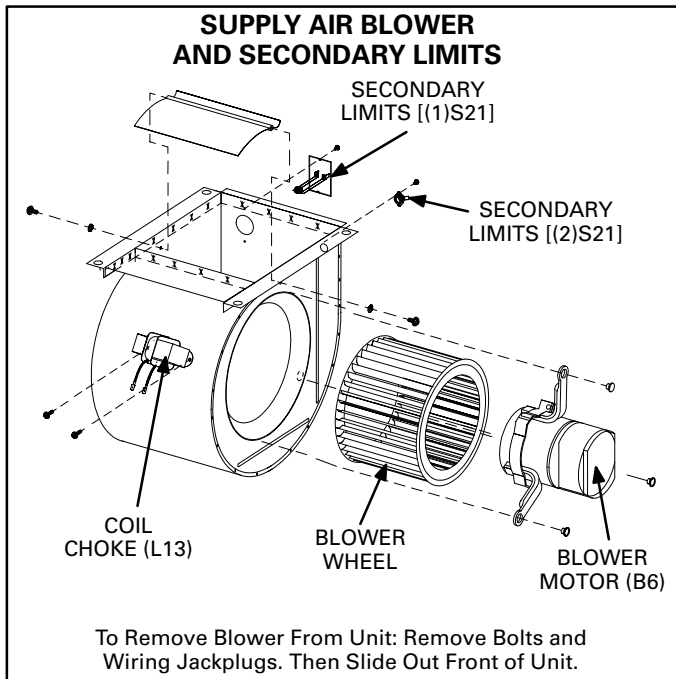
Located inside the blower compartment are the variable speed blower motor (B3), coil choke (L13), and the secondary limit switches [(1)S21 and (2)S21]. To access the blower compartment follow the steps outlined below:

- 1- Remove the two screws holding the blower panel to the unit.
- 2- Remove the two screws (located in the middle of the blower panel) holding the grommet for the VSP2 JP46 wires.
- 3- Disconnect the jack (J46) from the VSP2 and feed it through the blower panel.
- 4- Disconnect thermostat wires from the terminal strip (TB1) on the burner control board.
- 5- Disconnect the 120VAC (black) wire from the burner control board going to the coil choke and feed through the blower panel grommet.
- 6- Disconnect line voltage wire (white) and feed through the blower panel grommet.
- 7- Lift panel up and disconnect jack plugs JP1 and JP2 (brown wires) found in the blower compartment.

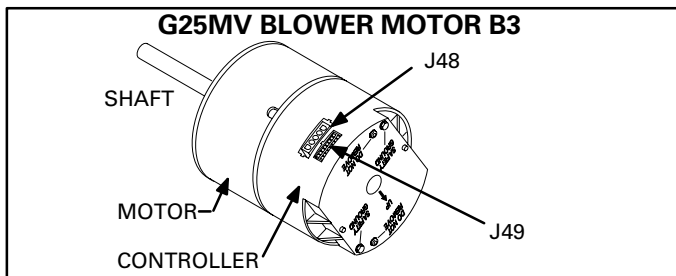


**FIGURE 7**

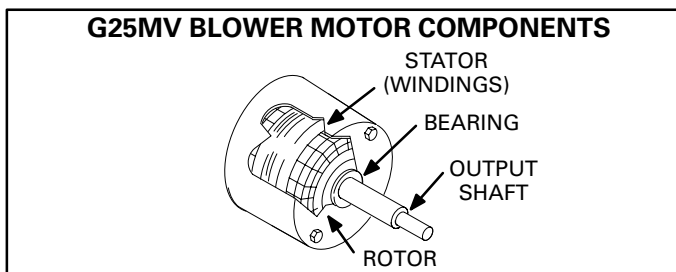
magnet rotor it does not need brushes like conventional D.C. motors. Internal components are shown in figure 10. The stator windings are split into three poles which are electrically connected to the controller. This arrangement allows motor windings to turn on and off in sequence by the controller.



**FIGURE 8**



**FIGURE 9**



**FIGURE 10**

A solid-state controller is permanently attached to the motor. The controller is primarily an A.C. to D.C. converter. Converted D.C. power is used to drive the motor. The controller contains a microprocessor which monitors varying conditions inside the motor (such as motor workload).

The controller uses sensing devices to sense what position the rotor is in at any given time. By sensing the position of the rotor and then switching the motor windings on and off in sequence, the rotor shaft turns the blower.

G25MV series blower motor ratings are listed in table 6. All G25MV blower motors use single phase power. An external run capacitor is not used. The motor uses permanently lubricated ball-type bearings.

**TABLE 6**  
**ELECTRONICALLY CONTROLLED BLOWER MOTOR**  
**CCW ROTATION**

Unit	Volts	Phase	HP
G25MV3	120	1	1/2
G25MV5	120	1	1

**Internal Operation**

Each time the controller switches a stator winding (figure 10) on and off, it is called a "pulse." The length of time each pulse stays on is called the "pulse width." By varying the pulse width (figure 11), the controller varies motor speed (called "pulse-width modulation"). This allows for precise control of motor speed and allows the motor to compensate for varying load conditions as sensed by the controller. In this case, the controller monitors the static workload on the motor and varies motor rpm in order to maintain constant airflow (cfm).

The motor is equipped with 11 incremental taps which are driven by the integral controller. The controller is capable of controlling three of the 11 taps.

The motor controller is driven by the VSP2. The VSP2 receives its demand (PWM signal or fixed 24 VAC or VDC signal) from optional controls such as the Harmony zone control system, Efficiency Plus Humidity Control (CCB1) or a conventional thermostat.

Motor rpm is continually adjusted internally to maintain constant static pressure against the blower wheel. The controller monitors the static work load on the motor and motor amp-draw to determine the amount of rpm adjustment. Blower rpm may be adjusted any amount in order to maintain a constant cfm as shown in Blower Ratings Tables. The amount of adjustment is determined by the incremental taps which are used and the amount of motor loading sensed internally. The cfm remains relatively stable over a broad range of static pressure. Since the blower constantly adjusts rpm to maintain a specified cfm, motor rpm is not rated. Hence, the terms "blower speed" and "speed tap" in this manual, on the unit wiring diagram and on blower B3 refer to blower cfm regardless of motor rpm.

When Harmony is used, speed taps are overridden and a PWM signal generated by the Harmony controller continuously varies motor speed based upon zone demands.

**Initial Power Up**

When line voltage is applied to B3, there will be a large inrush of power lasting less than 1/4 second. This inrush charges a bank of DC filter capacitors inside the controller. If the disconnect switch is bounced when the disconnect is closed, the disconnect contacts may become welded. Try not to bounce the disconnect switch when applying power to the unit.

The DC filter capacitors inside the controller are connected electrically to the speed tap wires. The capacitors take approximately 5 minutes to discharge when the disconnect is opened. For this reason it is necessary to wait at least 5 minutes after turning off power to the unit before attempting to change speed taps.

### Motor Start-Up




When B3 begins start-up, the motor gently vibrates back and forth for a moment. This is normal. During this time the electronic controller is determining the exact position of the rotor. Once the motor begins turning, the controller slowly eases the motor up to speed (this is called "soft-start"). The motor may take as long as 10-15 seconds to reach full speed. If the motor does not reach 200rpm within 13 seconds, the motor shuts down. Then the motor will immediately attempt a restart. The shutdown feature provides protection in case of a frozen bearing or blocked blower wheel. The motor may attempt to start eight times. If the motor does not start after the eighth try, the controller locks out. Reset controller by momentarily turning off power to unit.


⚠ DANGER

**Disconnect power from unit and wait at least five minutes to allow capacitors to discharge before attempting to adjust motor speed tap settings. Failure to wait may cause personal injury or death.**

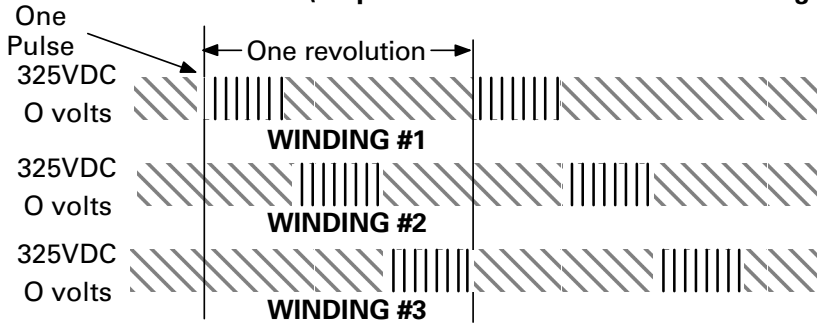
## MOTOR SPEED CONTROL WITH D.C. PULSE-WIDTH MODULATION

*Motor speed is determined by the size of the electrical pulse sent to the motor windings. The longer the pulse, the faster the motor.*

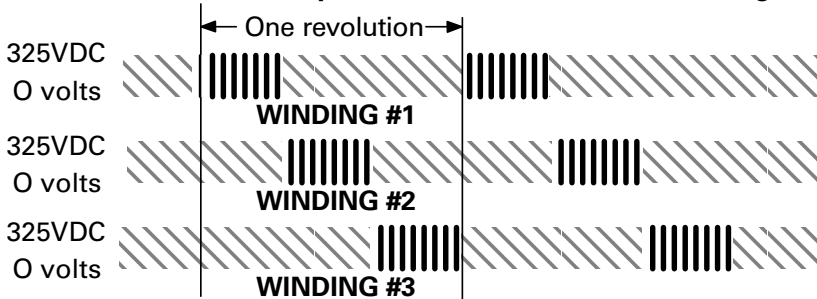
OUTPUT FROM CONTROLLER TO MOTOR WINDINGS	
WINDINGS TURNED OFF	WINDINGS TURNED ON
	 ON PULSE  OFF PULSE

The frequency of the pulses to the windings is 20KHz.  
DO NOT ATTEMPT TO MEASURE THESE VOLTAGES.

### LOW SPEED HEAT/COOL (output from controller to motor windings)



### HIGH SPEED HEAT (output from controller to motor windings)



### HIGH SPEED COOL (output from controller to motor windings)

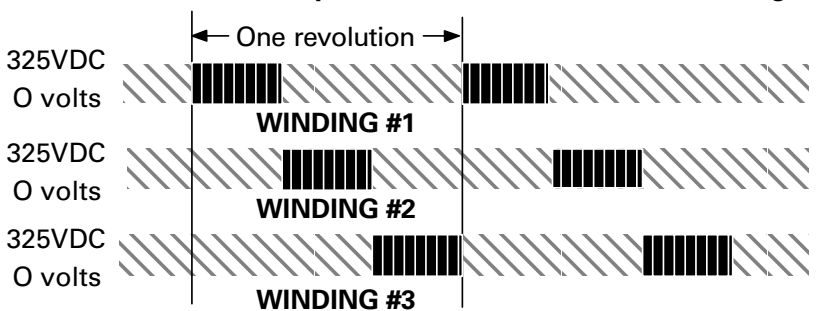


FIGURE 11

## External Operation (Speed Tap Priority)

Figure 12 shows the two quick-connect jacks (J48 and J49) which connect the motor to the G25MV. Jack J48 is the power plug and jack J49 connects the unit controls to the motor.

Line voltage must be applied to J48 pin 5 in order for the motor to operate. When using 120VAC pins 1 and 2 must be jumpered. When control voltage is applied to J49 pin 3 and 15 (single stage heating and cooling), the motor is energized on the low speed heat/cool tap.

When voltage is applied to J49 pin 2 in addition to pin 3 and 15 (second stage heating), the blower is energized on the high speed heating tap. When voltage is applied to J49 pin 10 in addition to pin 3 and 15 (second stage cooling), the blower is energized on the high speed heating tap. The motor assigns priority to J49 pin 2 so that if a call for cooling and a call for heating are concurrent, heating call overrides and the blower operates on high speed heating tap.

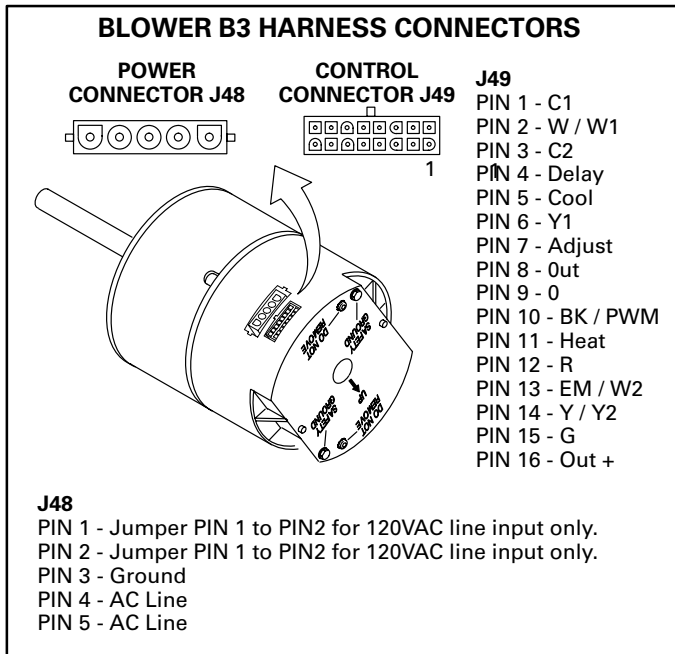


FIGURE 12

## **⚠ DANGER**

Do not attempt to repair electronically controlled blower motor or VSP2-1. There are no field serviceable parts. If either component appears to be faulty after following checkout procedure, replace entire component then recheck for proper operation.

## 2-Choke Coil (L13)

A choke coil is used on all G25MV units. The choke is located on the blower housing and is used to block radio frequency interference.

### Precautions

If the G25MV or its electronically controlled blower motor is improperly or inadequately grounded, it may cause television interference (commonly known as RFI or radio frequency interference).

This interference is caused by internal switching frequencies of the motor controller (see figure 13). TV interference may show up as small specks or lines which randomly appear on the TV screen accompanied by pops or clicks in the sound. Before attempting any service, make sure the indoor unit is causing the interference. To check, disconnect power to indoor unit then check TV for continued signs of interference.

TV interference may be stopped by making sure the motor is solidly grounded to the cabinet (metal to metal) and by making sure the cabinet is solidly grounded. If TV interference persists, make sure the television (and all affected RF appliances) are moved away from the G25MV. Also make sure affected appliances are connected to a separate electrical circuit.

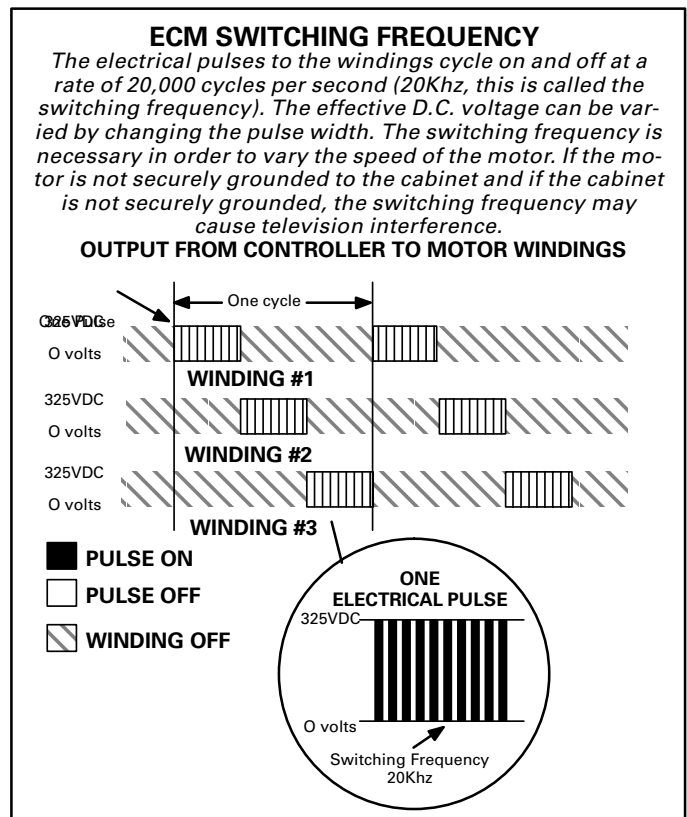


FIGURE 13

### 3-Secondary Limit Switches [(1)S21 and (2)S21]

The secondary limit switches [(1)S21 and (2)S21] on G25MV units are located in the blower compartment on the back side of the blower housing (see figure 8). When excess heat is sensed in the blower compartment, the limit will open. If the limit is tripped, the burner control energizes the supply air blower and closes the gas valve. The limit automatically resets when unit temperature returns to normal. Two limits are supplied in each furnace and each limit is a different style. Figure 14 shows both styles. Both switches are N.C. SPST auto-reset switches which actuate on a temperature rise. The switches are factory set and cannot be adjusted. The (1)S21 limit shown on the top opens at  $140^{\circ}\text{F} \pm 5^{\circ}\text{F}$  ( $60.0^{\circ}\text{C} \pm 2.8^{\circ}\text{C}$ ) on a temperature rise and closes at  $110^{\circ}\text{F} \pm 10^{\circ}\text{F}$  ( $43.3^{\circ}\text{C} \pm 5.6^{\circ}\text{C}$ ). The (2)S21 limit shown on the bottom opens at  $165^{\circ}\text{F} \pm 5^{\circ}\text{F}$  ( $73.9^{\circ}\text{C} \pm 2.8^{\circ}\text{C}$ ) on a temperature rise and closes at  $135^{\circ}\text{F} \pm 8^{\circ}\text{F}$  ( $57.2^{\circ}\text{C} \pm 4.4^{\circ}\text{C}$ ).

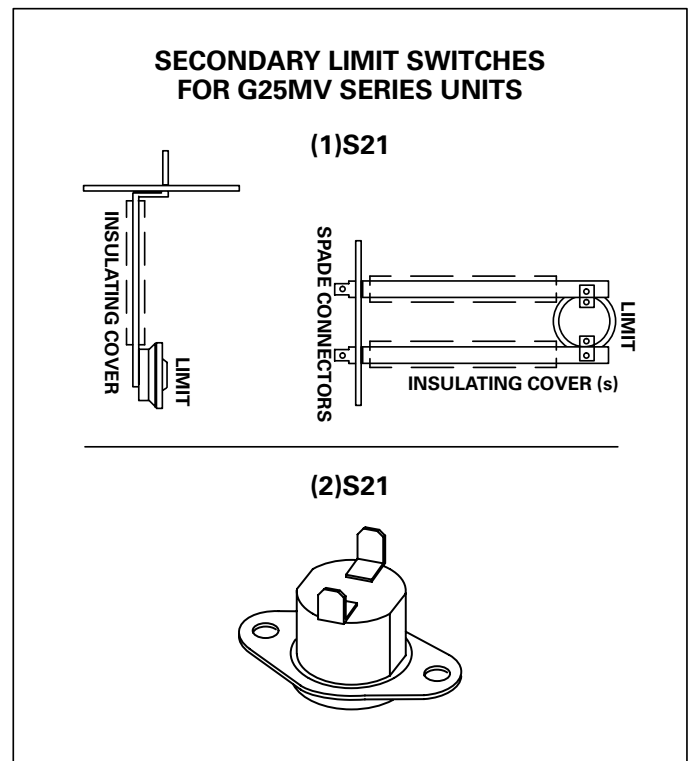


FIGURE 14

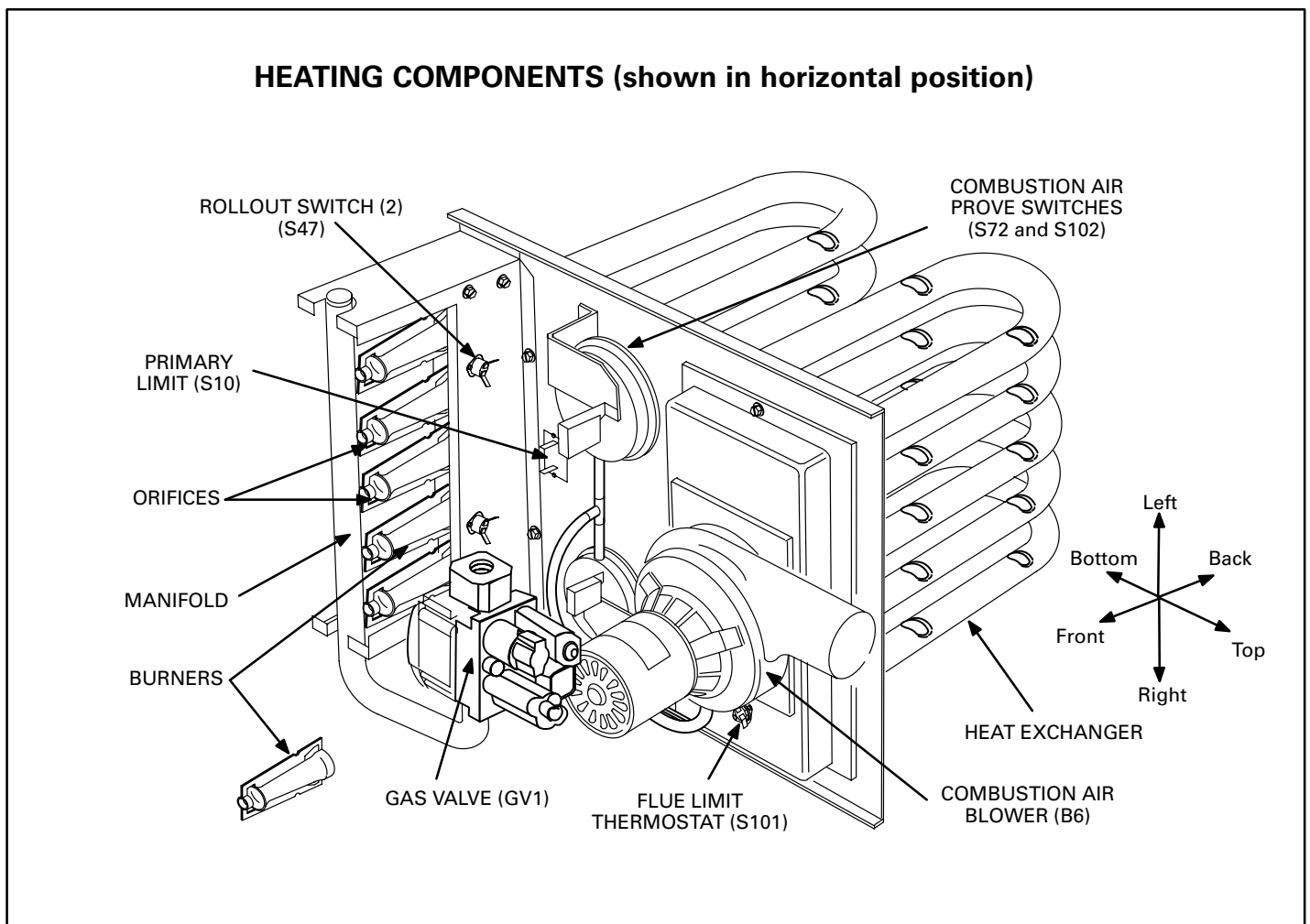
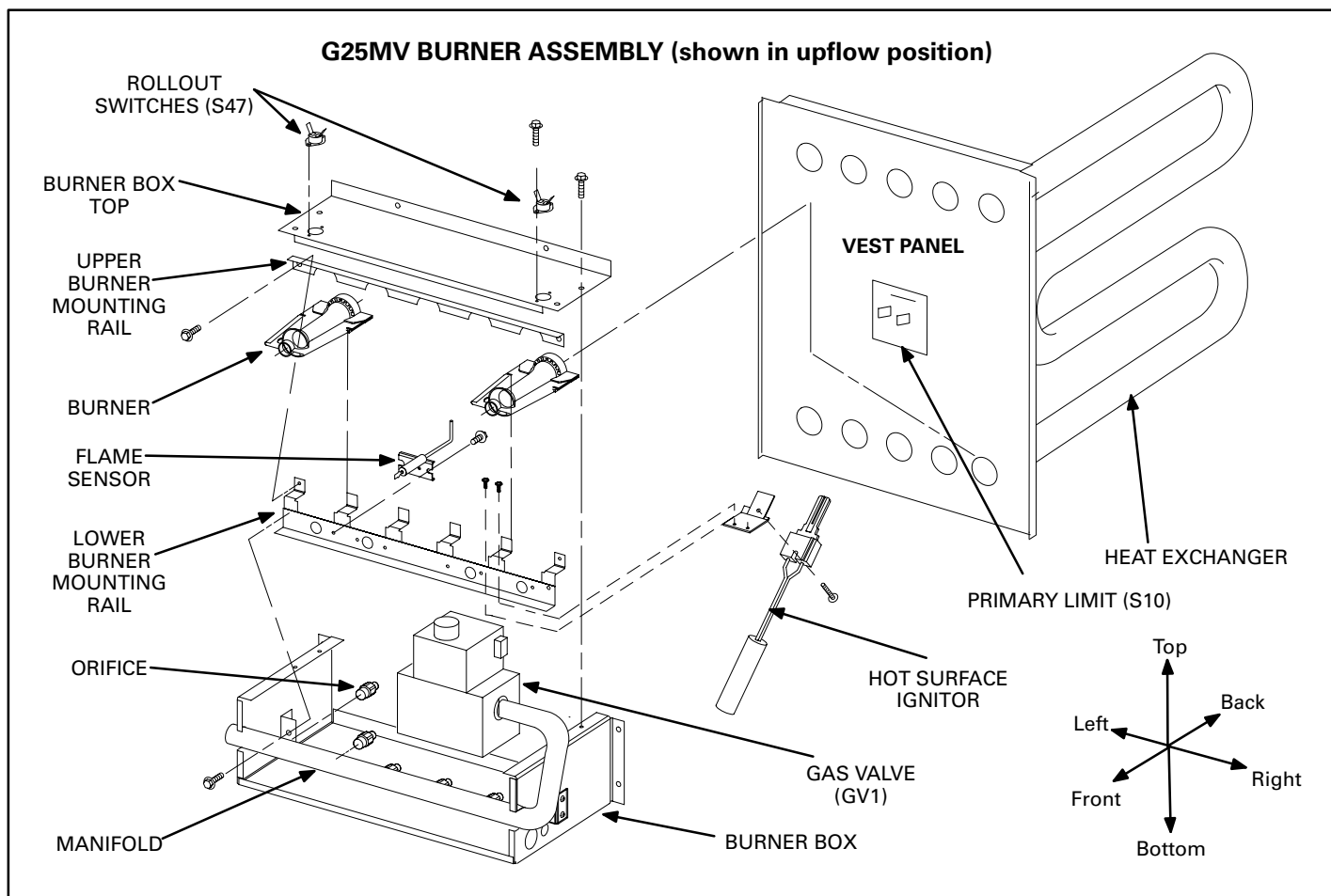


FIGURE 15



**FIGURE 16**

### **C-Heating Components (Figures 15 and 16)**

Heating components are located inside the front louvered panel. Inside the heating compartment are the combustion air blower (B6), flue limit thermostat (S101), flame rollout switches (S47), primary limit control (S10), ignitor, flame sensor, gas valve (GV1), and the combustion air blower prove switches (S72 and S102).

#### **1-Combustion Air Blower (B6)**

All G25MV units use a two stage combustion air blower to move air through the burners and heat exchanger during heating operation. The blower uses a 120VAC motor. The motor operates during all heating operation and is controlled by burner control A3. The blower also operates for 30 seconds before burner ignition (pre-purge) and for 5 seconds after the gas valve closes (post-purge).

#### **2-Flue Limit Thermostat (S101)**

Flue limit thermostat is a high temperature limit located on top of combustion air blower collector box (see figure 15). The limit is a N.C. SPST auto-reset limit which opens at  $200^{\circ}\text{F} \pm 5^{\circ}\text{F}$  ( $93.3^{\circ}\text{C} \pm 2.8^{\circ}\text{C}$ ) on a temperature rise and closes at  $160^{\circ}\text{F} \pm 8^{\circ}\text{F}$  ( $71.1^{\circ}\text{C} \pm 4.4^{\circ}\text{C}$ ). The switch

is factory set and cannot be adjusted. The limit is electrically connected to the burner control A3. The purpose of the limit is to set the unit to low fire when temperature reaches  $200^{\circ}\text{F}$  ( $93.3^{\circ}\text{C}$ ) in the heat exchanger on call for first stage heat.

#### **3-Flame Rollout Switches (S47)**

Flame rollout switch is a high temperature limit switch located on top of the burner box (see figure 16). Each furnace is equipped with two identical switches. One switch is located over the leftmost burner and the other switch is located over the rightmost burner. The switch is a N.C. SPST manual-reset switch which actuates at  $267^{\circ}\text{F} \pm 12^{\circ}\text{F}$  ( $130.5^{\circ}\text{C} \pm 6.7^{\circ}\text{C}$ ) on a temperature rise. The switch is factory set and cannot be adjusted. To manually reset a tripped switch, push the reset button located on the control. The switches are connected in series with the burner control A3. When S47 senses rollout, the burner control immediately stops ignition and closes the gas valve. If unit is running and flame rollout is detected, the gas valve will close and ignition control will be disabled. Rollout can be caused by a clogged heat exchanger or a blocked flue.

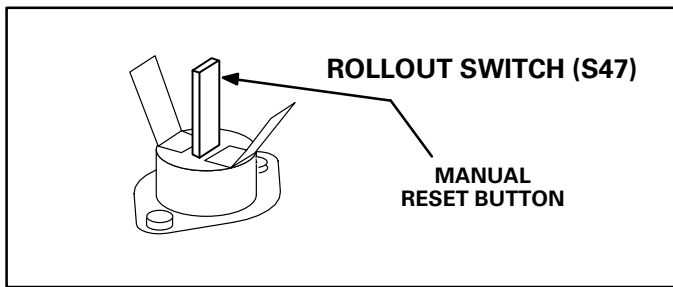


FIGURE 17

#### 4-Primary Limit Control (S10)

The primary limit (S10) on G25MV units is located in the middle of the heating vestibule panel (see figure 16). S10 is the same type of limit as shown on the top of figure 14. When excess heat is sensed in the heat exchanger, the limit will open. If the limit is tripped, the burner control energizes the supply air blower and closes the gas valve. The limit automatically resets when unit temperature returns to normal. The switch is factory set and cannot be adjusted. The switch has different setpoints for each unit model number. See table 7. The setpoint will also be printed on the side of the limit.

TABLE 7

PRIMARY LIMIT CONTROL (S10)		
UNIT	ACTUATE	TEMPERATURE
G25MV3-60	OPEN	200°F ± 5°F (93.3°C ± 2.8°C)
	CLOSE	170°F ± 8°F (76.7°C ± 4.4°C)
G25MV3-75	OPEN	175°F ± 5°F (79.4°C ± 2.8°C)
	CLOSE	145°F ± 8°F (62.8°C ± 4.4°C)
G25MV5-100	OPEN	190°F ± 10°F (87.8°C ± 5.6°C)
	CLOSE	160°F ± 8°F (71.1°C ± 4.4°C)
G25MV5-120	OPEN	150°F ± 5°F (65.6°C ± 2.8°C)
	CLOSE	120°F ± 8°F (48.9°C ± 4.4°C)

#### 5-Gas Valve (GV1)

The G25MV uses a gas valve manufactured by White Rodgers. The valve is a two-stage internally redundant to assure safety shut-off. If the gas valve must be replaced, the same type valve must be used.

24VAC terminals and gas control knob are located on top of the valve. All terminals on the gas valve are connected to wires from the electronic burner control. 24V applied to the terminals energizes the valve.

Inlet and outlet pressure taps are located on the valve. A regulator adjustment screw is located on the side of the valve. Refer to figure 18 for location of valve features.

*NOTE-Do not attempt to regulate low fire manifold pressure.*

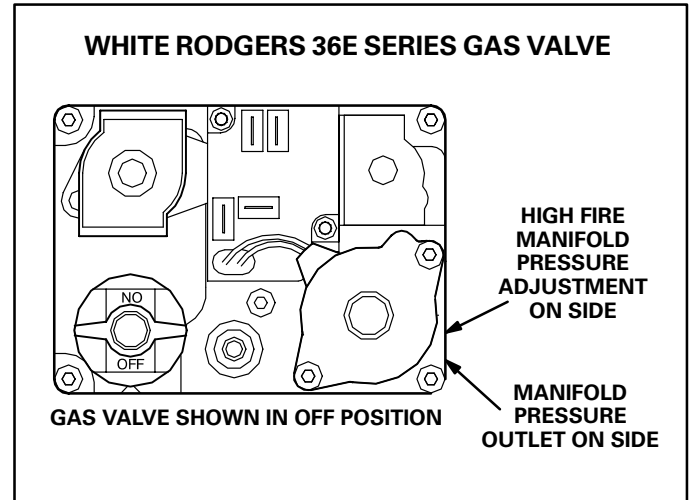


FIGURE 18

#### 6-Hot Surface Ignitor

Figure 20 shows the arrangement of the hot surface ignitor in perspective with the rest of the burner assembly. The burner control uses hot surface to ignite the two right-most burners and the burners cross-light to the left. A flame retention ring in the end of each burner is used to maintain correct flame length and shape and to keep the flame from lifting off the burner head. The hot surface ignitor is rated at 1800°F (982°C) in 17 seconds with a 120VAC 4 amp power source.

#### 7-Flame Sensor

Figure 20 shows the arrangement of flame sensor in perspective with the rest of the burner assembly. The flame sensor uses flame rectification to sense combustion. Figure 19 shows the gap between tip of the electrode and the burner surface.

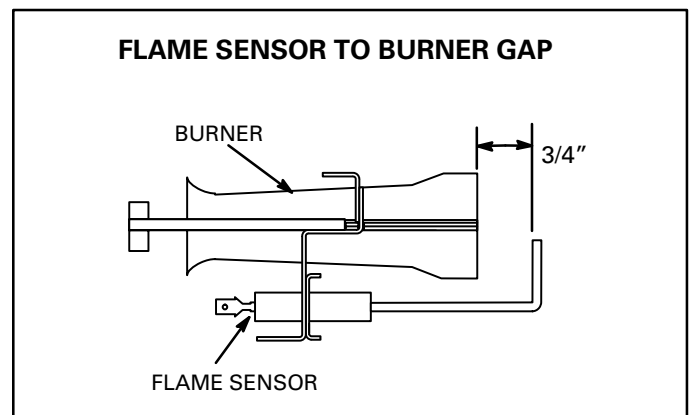


FIGURE 19



## **⚠ WARNING**

**Shock and burn hazard.**

**G25MV units are equipped with a hot surface ignition system. Do not attempt to light manually.**

- 4- Set fan switch to AUTO or ON and move system selection switch to HEAT. Adjust thermostat to a setting above room temperature.
- 5- If unit does not light the first time, it will attempt two more ignitions before locking out.
- 6- If lockout occurs, repeat steps 1, 2, 3 and 4.
- 7- On start-up check operation of both high and low fire. Refer to section IV item E for manifold pressure check procedure.

### **C-Safety or Emergency Shutdown**

Turn off unit power. Close manual and main gas valves.

### **D-Extended Period Shutdown**

Turn off thermostat or set to "UNOCCUPIED" mode. Close all gas valves (both internal and external to unit) to guarantee no gas leak into combustion chamber. Turn off power to unit. All access panels, covers and vent caps must be in place and secured.

## **IV-HEATING SYSTEM SERVICE CHECKS**

### **A-A.G.A. / C.G.A. Certification**

All G25MV units are A.G.A. / C.G.A. design certified without modifications. Refer to the G25MV Operation and Installation Instruction Manual for Information.

### **B-Gas Piping**

Gas supply piping should not allow more than 0.5" W.C. drop in pressure between gas meter and unit. Supply gas pipe must not be smaller than unit gas connection.

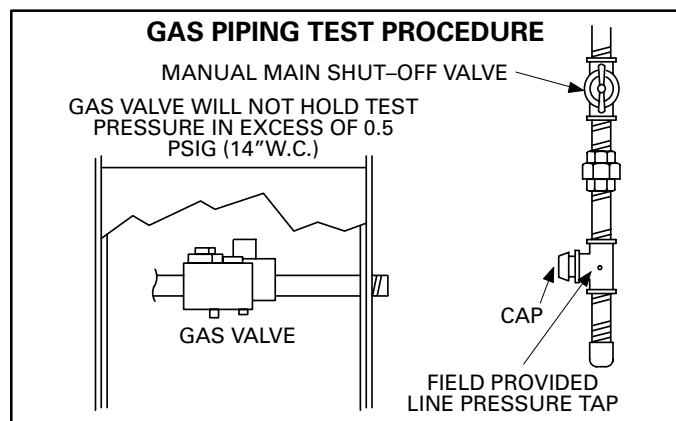
Compounds used on gas piping threaded joints should be resistant to action of LP gases.

### **C-Testing Gas Piping**

## **⚠ IMPORTANT**

**In case emergency shutdown is required, turn off the main shut-off valve and disconnect the main power to unit. These controls should be properly labeled by the installer.**

When pressure testing gas lines, the gas valve must be disconnected and isolated. Gas valves can be damaged if subjected to more than 0.5psig (14" W.C.). See figure 22. If the pressure is equal to or less than 0.5psig (14" W.C.), use the manual shut-off valve before pressure testing to isolate furnace from gas supply.



**FIGURE 22**

When checking piping connections for gas leaks, use preferred means. Kitchen detergents can cause harmful corrosion on various metals used in gas piping. Use of a specialty Gas Leak Detector is strongly recommended. It is available through Lennox under part number 31B2001. See Corp. 8411-L10, for further details.

Do not use matches, candles, flame or any other source of ignition to check for gas leaks.

### **D-Testing Gas Supply Pressure**

When testing supply gas pressure, connect test gauge to inlet pressure tap (field provided). See figure 22. Check gas line pressure with unit firing at maximum rate. Low pressure may result in erratic operation or underfire. High pressure can result in permanent damage to gas valve or overfire. For natural gas units, operating pressure at unit gas connection must be a minimum of 4.5" W.C.

On multiple unit installations, each unit should be checked separately, with and without other units operating. Supply pressure must be a minimum of 4.5" W.C. for each unit.

### **E-Check Manifold Pressure**

After line pressure has been checked and adjusted, check manifold pressure. Move pressure gauge to outlet pressure tap located on unit gas valve (GV1). Checks of manifold pressure are made as verification of proper regulator adjustment. Manifold pressure for the G25MV can be measured at any time the gas valve is open and is supplying gas to the unit. Normal manifold pressure for natural gas units is 3.5" W.C. (870.2 Pa) for high fire operation and 1.7" W.C. (422.7 Pa) for low fire.

## **⚠ IMPORTANT**

**For safety, connect a shut-off valve between the manometer and the gas tap to permit shut off of gas pressure to the manometer.**

The gas valve is factory set and should not require adjustment. All gas valves are factory regulated.

### Manifold Pressure Check Procedure:

- 1- Connect a test gauge to outlet pressure tap on gas valve. Start unit and allow 5 minutes for unit to reach steady state.
- 2- While waiting for the unit to stabilize, notice the flame. Flame should be stable and should not lift from burner. Natural gas should burn blue.
- 3- After allowing unit to stabilize for 5 minutes, record manifold pressure and compare to the normal manifold pressure of 3.5" W.C. (870.2 Pa) for high fire operation or 1.7" W.C. (422.7 Pa) for low fire.

*NOTE—Shut unit off, turn gas valve to "OFF" position and remove manometer as soon as an accurate reading has been obtained. Take care to replace pressure tap plug.*

### F- Proper Gas Flow

To check for proper gas flow to combustion chamber, determine Btuh input from unit rating plate or the specifications tables on page 2. Divide input rating by Btuh per cubic foot of available gas. Result is the number of cubic feet per hour required. Determine flow of gas through gas meter for two minutes. Multiply by 30 to get hourly flow of gas to burner.

*NOTE—To obtain accurate reading, shut off all other gas appliances connected to meter.*

### G-High Altitude Derate

A.G.A. certified units must be derated 4 percent for each 1,000 feet (305m) above sea level. Thus, at an altitude of 4000 feet (1210 m), the unit would require a derate of 16 percent.

C.G.A. certified units must be derated 10 percent for elevations 2000 feet (610 m) to 4500 feet (1370 m) above sea level.

*NOTE—In Canada, use the following high altitude conversion kits: LB-79766A for G25MV3-60/75; and LB-79766B for G25MV5-100/120.*

*NOTE—This is the only permissible field derate for this appliance.*

## ⚠ IMPORTANT

**For safety, shut unit off and remove manometer as soon as an accurate reading has been obtained. Take care to replace pressure tap plug.**

### H-Flame Signal

A 20 microamp DC meter is needed to check the flame signal on the primary ignition control. Use a flame signal transducer (part number 78H5401) available from Lennox to measure the flame signal.

Flame (microamp) signal is an electrical current which passes from the ignition control through the sensor electrode during unit operation. Current passes from the sensor through the flame to ground to complete a safety circuit.

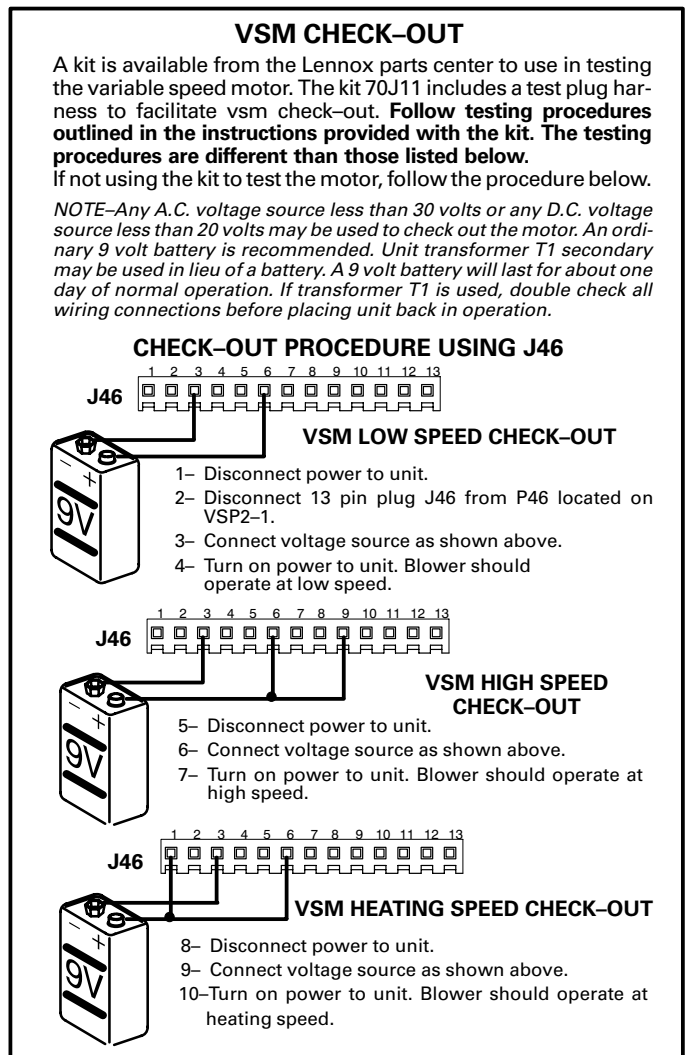
### To Measure Flame Signal:

- 1- Remove front louvered panel and disconnect the sensor wire from the flame sensor.
- 2- Place meter in series between flame sensor and sensor wire. Connect the positive (+) lead of meter to the sensor wire and the negative (-) lead of the meter to the flame sensor.
- 3- Set thermostat for a heating demand and check flame signal with unit operating. For G25MV series, a reading of 4 to 6 microamps DC should occur. The ignition control must see at least 1.5 microamps in order to keep the gas valve energized.

Flame signal may rise above 5 microamps for the first few seconds after ignition then level off within the range.

### I-Electronically Controlled Blower Motor

To check-out the VSM blower and the VSP2-1 blower control board, begin with the VSM blower. Refer to figure 23 and follow the check-out procedure as outlined. If the blower fails any of these tests, do not attempt to repair the VSM blower. There are no field serviceable parts in this component. Replace the motor and repeat the check-out procedure. To verify proper operation of the VSP2-1, check the board as outlined in the troubleshooting flow-charts on the last page.



**FIGURE 23**

## V-TYPICAL OPERATING CHARACTERISTICS

### A-Blower Operation and Adjustment

*NOTE- The following is a generalized procedure and does not apply to all thermostat controls.*

- 1- Blower operation is dependent on thermostat control system.
- 2- Generally, blower operation is set at thermostat subbase fan switch. With fan switch in ON position, blower operates continuously on heating speed. With fan switch in AUTO position, blower cycles with demand or runs continuously while heating or cooling circuit cycles.
- 3- In all cases, blower and entire unit will be off when the system switch is in OFF position.

### B-Temperature Rise

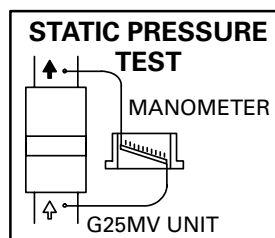
Temperature rise for G25MV units depends on unit input, blower speed, blower horsepower and static pressure as marked on the unit rating plate. The blower speed must be set for unit operation within the range of "AIR TEMP. RISE °F" listed on the unit rating plate.

#### To Measure Temperature Rise:

- 1- Place plenum thermometers in the supply and return air plenums. Locate supply air thermometer in the first horizontal run of the plenum where it will not pick up radiant heat from the heat exchanger.
- 2- Set thermostat to highest setting.
- 3- After plenum thermometers have reached their highest and steadiest readings, subtract the two readings. The difference should be in the range listed on the unit rating plate. If the temperature is too low, decrease blower speed. If temperature is too high, first check the firing rate. Provided the firing rate is acceptable, increase blower speed to reduce temperature. To change blower speed taps see the Blower Speed Taps section in this manual.

### C-External Static Pressure

- 1- Measure tap locations as shown in figure 24.
- 2- Punch a 1/4" diameter hole in supply and return air plenums. Insert manometer hose flush with inside edge of hole or insulation. Seal around the hose with permagum. Connect the zero end of the manometer to the discharge (supply) side of the system. On ducted systems, connect the other end of manometer to the return duct as above. For systems with non-ducted returns, leave the other end of the manometer open to the atmosphere.



**FIGURE 24**

- 3- With only the blower motor running and the evaporator coil dry, observe the manometer reading. Adjust blower motor speed to deliver the air desired according to the job requirements.
- 4- External static pressure drop must not be more than 0.8" W.C. (198.9 Pa).
- 5- Seal around the hole when the check is complete.

## VI-MAINTENANCE

At the beginning of each heating season, the system should be checked as follows:

### A-Filters

Return air filter is supplied with unit. A filter must be used in order to ensure long life and proper operation. The filter is located in the return air duct or return air register. Filters must be cleaned or replaced when dirty to assure proper unit operation.

### B-Cleaning Heat Exchanger and Burners

*NOTE-Use papers or protective covering in front of furnace while cleaning furnace.*

#### To clean heat exchanger and burners:

- 1- Turn off both electrical and gas power supplies to furnace. Refer to figure 1 during disassembly and reassembly procedures.
- 2- Disconnect wires leading to burner and heat exchanger assembly.
- 3- Remove front louvered panel and blower access panels.
- 4- Remove flue pipe and draft hood.
- 5- Disconnect gas piping and move piping out of way so heat exchanger can slide out front of cabinet.
- 6- Gas manifold, gas valve, burners and combustion air blower do not need to be removed and can be left in place.
- 7- Locate four screws which hold heat exchanger in place (two on each side of cabinet). See figure 25. Remove screws.
- 8- Slide heat exchanger out of cabinet.

#### To clean burners:

- 9- Remove screws holding upper burner mounting rail (figure 16). Remove rail.
- 10- Slide burners off each orifice and pull burners from heat exchanger.
- 11- Clean holes in burner head (retention ring) with a wire brush. See figure 20.
- 12- With a shop vacuum or rags, clean out soot and scale deposits from burners.
- 13- Remove screws securing flue box to vestibule panel. Remove flue box from unit. Leave combustion air blower attached to flue box.
- 14- With a shop vacuum or rags, clean out soot and scale deposits from heat exchanger tubes and flue box.
- 15- Inspect heat exchanger for corrosion damage, holes or cracks.

- 16– Replace burners making sure to fully engage on orifice. Resecure burner mounting rail and flue box. Inspect flue box gasket. Replace gasket if necessary.
- 17– Slide heat exchanger into cabinet and re-secure heat exchanger screws.
- 18– Re-secure flue pipe, gas piping and access panels.
- 19– Carefully check all piping connections (factory and field) for gas leaks. Use a leak detecting solution or other preferred means.
- 20– Turn on gas and electrical supply.

## C–Supply Air Blower

Check and clean blower wheel. Motors are prelubricated for extended life; no further lubrication is required.

## B – Flue and Chimney

Flue must conform to all AGA/GAMA venting requirements. Flue pipe deteriorates from the inside out and must be disconnected in order to check thoroughly. Check flue pipe, chimney and all connections for tightness and to make sure there is no blockage or leaks.

## ⚠ CAUTION

**Potential for gas leaks, fire or explosion. Some soaps used for leak detection are corrosive to certain metals. Carefully clean piping thoroughly after leak detection has been completed. Can cause damage to piping resulting in gas leaks, fire or explosion.**

## C – Electrical

- 1 – Check all wiring for loose connections.
- 2 – Check for correct voltage.
- 3 – Check amp–draw on blower motor.

## HEAT EXCHANGER REMOVAL (unit shown in horizontal position)

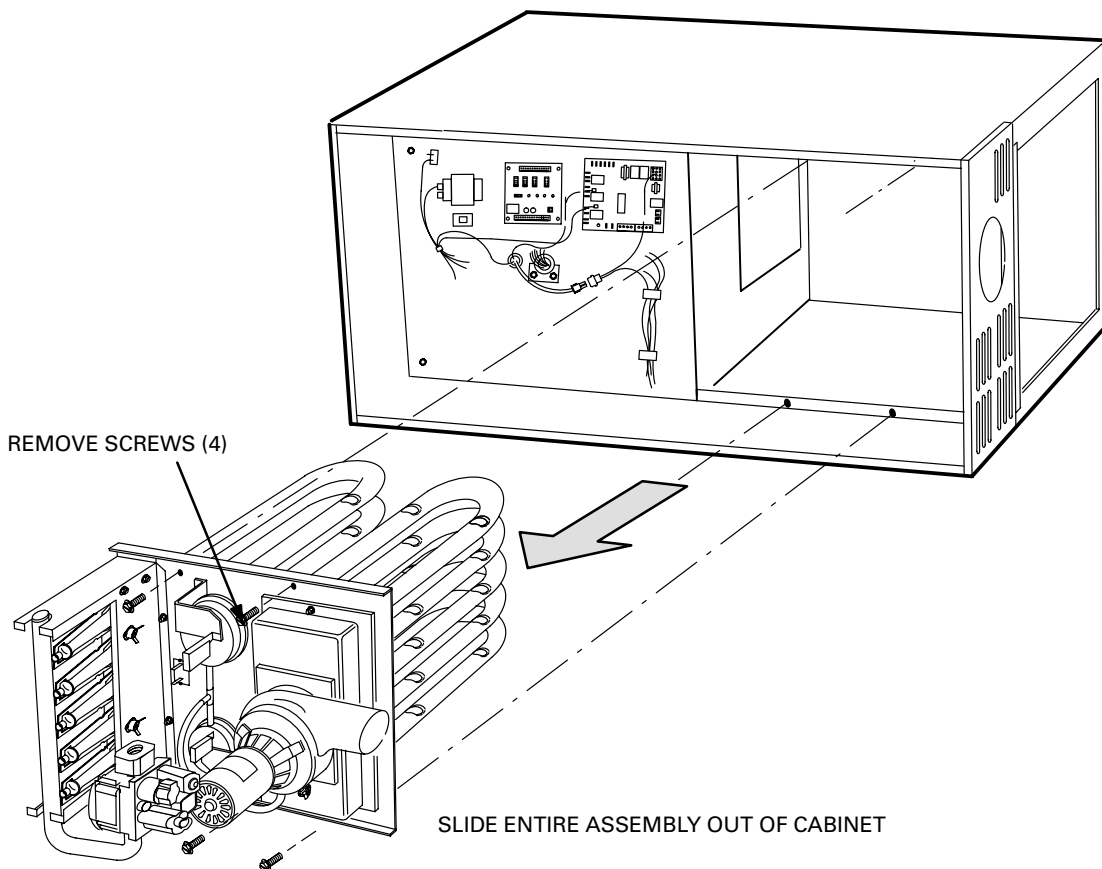


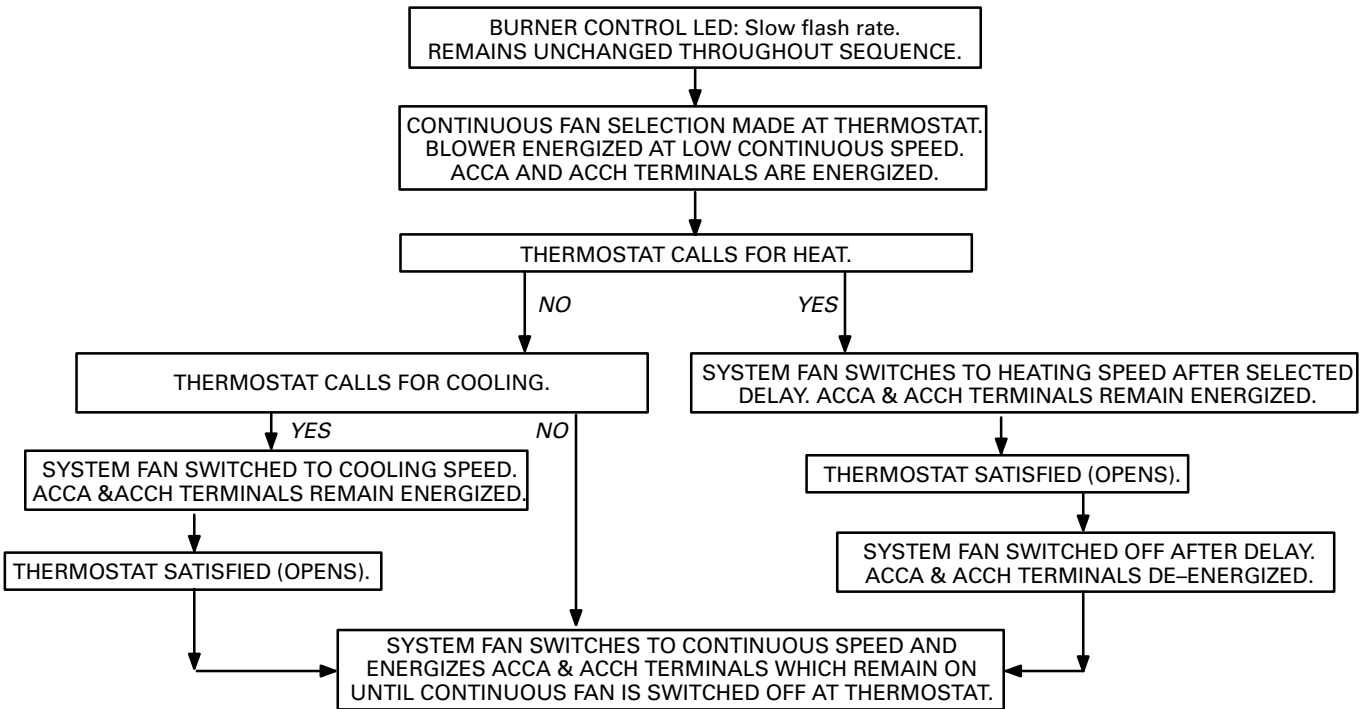
FIGURE 25



## COOLING SEQUENCE OF OPERATION



## CONTINUOUS FAN SEQUENCE OF OPERATION



BURNER CONTROL LED CODES	
SLOW FLASH	NORMAL OPERATION. NO CALL FOR HEAT.
FAST FLASH	NORMAL OPERATION. CALL FOR HEAT.
2 FLASH	SYSTEM LOCKOUT. FAILURE TO DETECT OR SUSTAIN FLAME.
3 FLASH	PRESSURE SWITCH OPEN OR CLOSED.
4 FLASH	HIGH LIMIT OR ROLLOUT SWITCH OPEN.
5 FLASH	FLAME SENSED AND GAS VALVE NOT ENERGIZED.
6 FLASH	FAILED HOT SURFACE IGNITOR
STEADY ON	CONTROL BOARD FAILURE.

**NORMAL HEATING MODE**

BURNER CONTROL LED: SLOW FLASH RATE

THERMOSTAT CALLS FOR HEAT (W1)

BURNER CONTROL LED: FAST FLASH RATE

FLAME OFF?

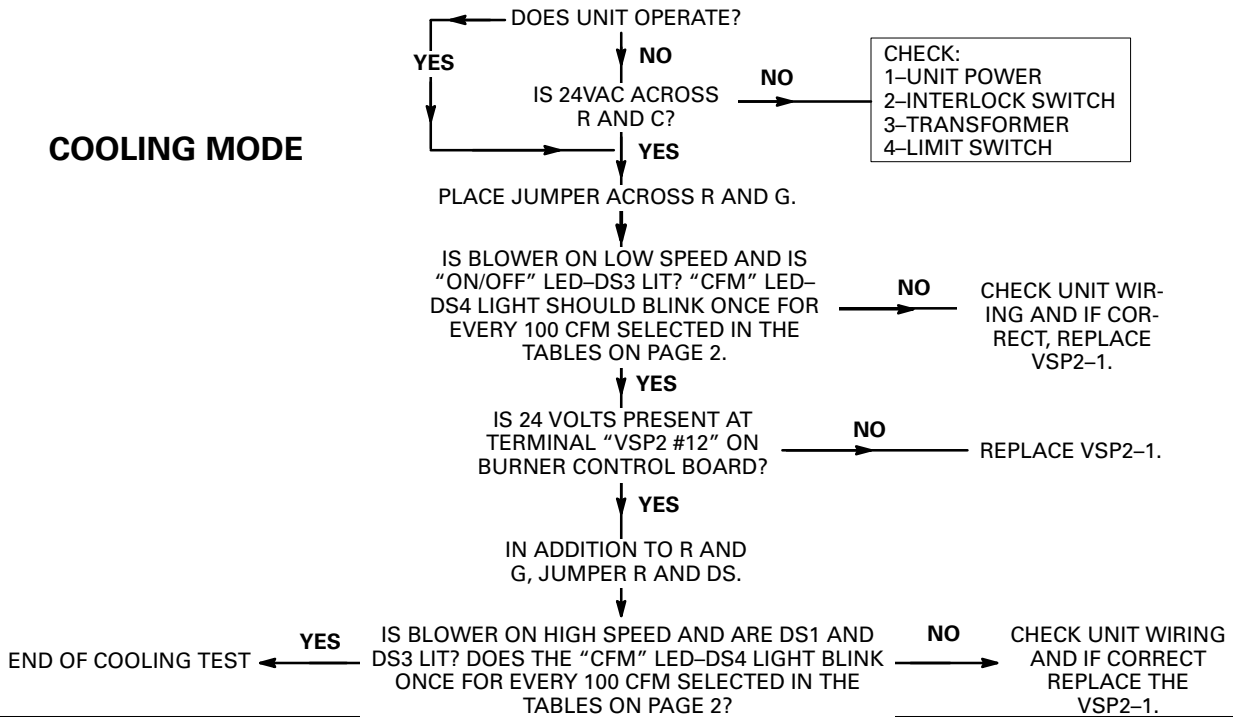
**HEATING SEQUENCE OF OPERATION**

**ABNORMAL HEATING MODE**

FLUE THERMOSTAT OPEN?

## G25MV VSM BLOWER AND VSP2-1 BLOWER CONTROL BOARD TROUBLESHOOTING FLOW CHART

### COOLING MODE



### HEATING MODE

