

C0A/C2A Condensing Units

**1.5 thru 5 Tons (5.3 to 17.6 kW)
18,000 to 57,500 Btuh (5.3 to 16.9 kW) Cooling Capacity**

SERVICE MANUAL

**RETAIN THESE INSTRUCTIONS
FOR FUTURE REFERENCE**

**Corp. 9911-L4
Revised 07/99**

C0A/C2A SERIES UNITS

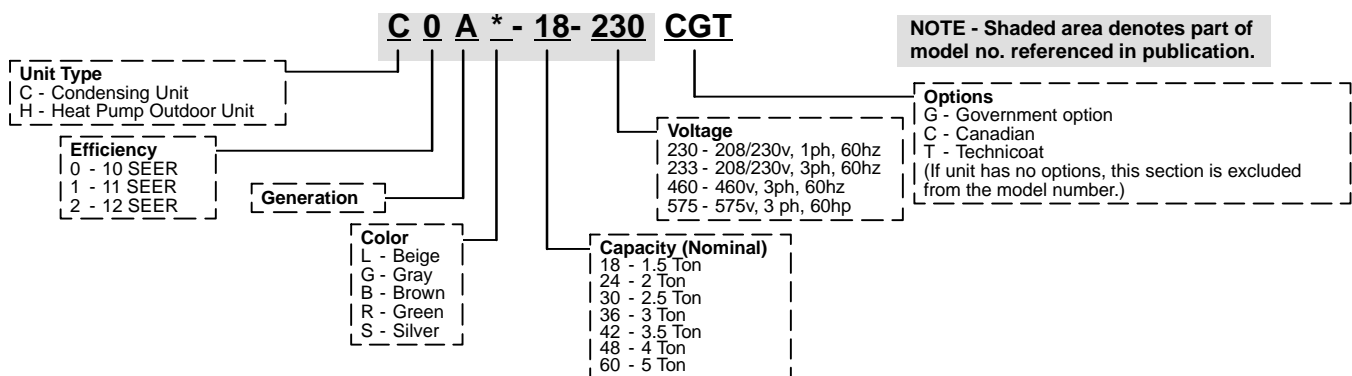

The C0A is a residential split-system condensing unit. Condensing coil size, circuiting and air volume result in a minimum SEER rating of 10.0. The series is designed for use with an expansion valve or orifice system in the indoor unit.

All C0A 1-1/2 to 3 ton units utilize reciprocating compressors. All C0A 3-1/2 to 5 ton units utilize scroll compressors. It operates much like a standard condensing unit, but the C0A's scroll compressor is unique in the way that it compresses refrigerant. Compressors are hermetically sealed for long service life. The compressor is installed in the unit on resilient rubber mounts to assure quiet, vibration-free operation. A built-in protection device assures protection from excessive current and temperatures.

Several models are available in sizes ranging from 1-1/2 through 5 tons.

The C2A is a residential split-system condensing unit. The series is designed for use with expansion valve systems. All C2A units utilize scroll compressors. It operates much like a standard condensing unit, but the C2A's scroll compressor is unique in the way that it compresses refrigerant. Several models are available in sizes ranging from 2 through 5 tons.

This manual is divided into sections which discuss the major components, refrigerant system, charging procedure, maintenance and operation sequence.

All specifications in this manual are subject to change.

SPECIFICATIONS C0A

Model No.		C0A*-18-230	C0A*-24-230	C0A*-30-230	C0A*-36-230
Nominal Tonnage (kW)		1.5 (5.3)	2 (7.0)	2.5 (8.8)	3 (10.6)
Liquid line - o.d. connection (sweat) - in. (mm)		3/8 (9.5)	3/8 (9.5)	3/8 (9.5)	3/8 (9.5)
Suction line - o.d. connection (sweat) - in. (mm)		5/8 (15.9)	5/8 (15.9)	3/4 (19.1)	3/4 (19.1)
① Refrigerant charge furnished (HCFC-22)	lbs.	4 lbs. 0 oz.	4 lbs. 9 oz.	5 lbs. 0 oz.	4 lbs. 14 oz.
	kg	1.81	2.07	2.27	2.21
Condenser Coil	Net face area - sq. ft. (m ²)	10.46 (0.97)	10.46 (0.97)	10.46 (0.97)	11.41 (1.06)
	Tube diameter - in. (mm)	5/16 (7.9)	5/16 (7.9)	5/16 (7.9)	5/16 (7.9)
	No. of rows	1	1	1	1
	Fins per inch (m)	18 (709)	18 (709)	18 (709)	22 (866)
Condenser Fan	Diameter - in. (mm)	18 (457)	18 (457)	18 (457)	18 (457)
	No. of blades	3	3	3	3
	Motor hp (W)	1/6 (124)	1/6 (124)	1/6 (124)	1/4 (187)
	Cfm (L/s)	2170 (1025)	2170 (1025)	2170 (1025)	2510 (1185)
	Rpm	1100	1100	1100	1103
	Watts	254	254	254	266
Shipping weight - lbs. (kg) 1 package		136 (62)	136 (62)	136 (62)	140 (64)

OPTIONAL ACCESSORIES C0A

Compressor Crankcase Heater	68887	68887	68887	68887
Compressor Monitor (Optional for Canada Only)	45F08	45F08	45F08	45F08
Hail Guards	17L71	17L71	17L71	17L73
Low Ambient Kit - for use with expansion valve systems only	24H77	24H77	24H77	24H77
Mounting Base	69J06	69J06	69J06	69J06
Timed-Off Control	47J27	47J27	47J27	47J27
Unit Stand Off Kit	94J45	94J45	94J45	94J45
Compressor Sound Cover	69J1701	69J1701	69J1701	53J3901

*Variable field

① Refrigerant charge sufficient for 20 ft. (6.0 m) length of refrigerant lines.

SPECIFICATIONS C0A

Model No.		C0A*-42-230	C0A*-48-230	C0A*-60-230
Nominal Tonnage (kW)		3.5 (12.3)	4 (14.1)	5 (17.6)
Liquid line - o.d. connection (sweat) - in. (mm)		3/8 (9.5)	3/8 (9.5)	3/8 (9.5)
Suction line - o.d. connection (sweat) - in. (mm)		7/8 (22.2)	7/8 (22.2)	1-1/8 (28.6)
① Refrigerant charge furnished (HCFC-22)	lbs.	5 lbs. 12 oz.	7 lbs. 4 oz.	8 lbs. 6 oz.
	kg	2.61	3.29	3.80
Condenser Coil	Net face area - sq. ft. (m ²)	Outer coil	13.31 (1.24)	15.11 (1.40)
		Inner coil	-----	5.4 (0.50)
	Tube diameter - in. (mm)	5/16 (7.9)	5/16 (7.9)	5/16 (7.9)
	No. of rows	1	1	1
Fins per inch (m)		22 (866)	22 (866)	22 (866)
Condenser Fan	Diameter - in. (mm)	18 (457)	18 (457)	22 (559)
	No. of blades	4	4	4
	Motor hp (W)	1/3 (249)	1/3 (249)	1/3 (249)
	Cfm (L/s)	2800 (1320)	2950 (1390)	3900 (1840)
	Rpm	1116	1100	1100
Watts		299	310	367
Shipping weight - lbs. (kg) 1 package		138 (63)	196 (890)	199 (90)

OPTIONAL ACCESSORIES C0A

Compressor Crankcase Heater	90P12	90P12	90P12
Compressor Monitor (Optional for Canada Only)	45F08	45F08	45F08
Hail Guards	17L73	17L73	17L73
Low Ambient Kit - for use with expansion valve systems only	24H77	24H77	24H77
Mounting Base	69J06	69J06	69J06
Timed-Off Control	47J27	47J27	47J27
Unit Stand Off Kit	94J45	94J45	94J45
Compressor Sound Cover	69J0301	69J0301	69J0301

*Variable field

① Refrigerant charge sufficient for 20 ft. (6.0 m) length of refrigerant lines.

ELECTRICAL DATA C0A

Model No.		C0A*-18-230	C0A*-24-230	C0A*-30-230	C0A*-36-230	C0A*-42-230	C0A*-48-230	C0A*-60-230
Line voltage data - 60 hz - 1 phase		208/230v	208/230v	208/230v	208/230v	208/230v	208/230v	208/230v
Rec. max. fuse/circuit breaker size (amps)		20	25	30	35	40	50	60
☐ Minimum circuit ampacity		11.7	14.4	17.2	20.4	24.3	29.2	33.2
Compressor	Rated load amps	7.95	10.1	12.4	14.9	17.9	21.8	25
	Locked rotor amps	48.3	60	69.4	96	103	103	170
	Power factor	0.97	0.96	0.92	0.89	0.84	0.80	0.90
Condenser Coil Fan Motor	Full load amps	1.1	1.1	1.1	1.7	1.9	1.9	1.9
	Locked rotor amps	1.9	1.9	1.9	3.1	4.1	4.1	4.1

*Variable Field.

☐ Refer to National or Canadian Electrical Code manual to determine wire, fuse and disconnect size requirements.

NOTE — Extremes of operating range are plus 10% and minus 5% of line voltage.

☐ Most popular evaporator coil match.

SPECIFICATIONS C2A

Model No.		C2A*-24-230	C2A*-30-230	C2A*-36-230	
Nominal Tonnage (kW)		2 (7.0)	2.5 (8.8)	3 (10.6)	
Liquid line - o.d. connection (sweat) - in. (mm)		3/8 (9.5)	3/8 (9.5)	3/8 (9.5)	
Suction line - o.d. connection (sweat) - in. (mm)		3/4 (19.1)	3/4 (19.1)	7/8 (22.2)	
☐ Refrigerant charge furnished (HCFC-22)	lbs.	5 lbs. 8 oz.	7 lbs. 3 oz.	7 lbs. 4 oz.	
	kg	2.49 kg	3.26 kg	3.29 kg	
Condenser Coil	Net face area - sq. ft. (m ²)	Outer coil	15.21 (1.41)	15.21 (1.41)	15.21 (1.41)
		Inner coil	5.44 (0.51)	14.50 (1.35)	14.50 (1.35)
	Tube diameter - in. (mm)	5/16 (7.9)	5/16 (7.9)	5/16 (7.9)	
	No. of rows	1.37	2	2	
Fins per inch (m)		22 (866)	22 (866)	22 (866)	
Condenser Fan	Diameter - in. (mm)	18 (457)	18 (457)	18 (457)	
	No. of blades	3	4	4	
	Motor hp (W)	1/6 (124)	1/6 (124)	1/6 (124)	
	Cfm (L/s)	2500 (1180)	2450 (1155)	2450 (1155)	
	Rpm	1100	1100	1100	
	Watts	200	200	200	
Shipping weight - lbs. (kg) 1 package		155 (70)	175 (79)	180 (82)	

OPTIONAL ACCESSORIES C2A

Compressor Crankcase Heater	90P12	90P12	90P12
Compressor Sound Cover	69J0301	69J0301	69J0301
Hail Guards	17L73	17L73	17L73
Low Ambient Kit - for use with expansion valve systems only	24H77	24H77	24H77
Mounting Base	69J06	69J06	69J06
Timed-Off Control	47J27	47J27	47J27
Unit Stand Off Kit	94J45	94J45	94J45
Compressor Monitor (Optional for Canada Only)	45F08	45F08	45F08

*Variable field

☐ Refrigerant charge sufficient for 20 ft. (6.0 m) length of refrigerant lines.

SPECIFICATIONS C2A

Model No.		C2A*-42-230	C2A*-48-230	C2A*-60-230
Nominal Tonnage (kW)		3.5 (12.3)	4 (14.1)	5 (17.6)
Liquid line - o.d. connection (sweat) - in. (mm)		3/8 (9.5)	3/8 (9.5)	3/8 (9.5)
Suction line - o.d. connection (sweat) - in. (mm)		7/8 (22.2)	7/8 (22.2)	1-1/8 (28.6)
☐ Refrigerant charge furnished (HCFC-22)		lbs.	7 lbs. 11 oz.	10 lbs. 14 oz.
		kg	3.49 kg	4.93 kg
Condenser Coil	Net face area - sq. ft. (m ²)	Outer coil	15.21 (1.41)	21.11 (1.96)
		Inner coil	14.50 (1.35)	20.31 (1.89)
	Tube diameter - in. (mm) & no. of rows		5/16 (7.9)	5/16 (7.9)
	No. of rows		2	2
	Fins per inch (m)		22 (866)	22 (866)
Condenser Fan	Diameter - in. (mm)		18 (457)	22 (559)
	No. of blades		4	4
	Motor hp (W)		1/3 (249)	1/3 (249)
	Cfm (L/s)		2930 (1385)	3890 (1835)
	Rpm		1100	1085
	Watts		310	375
Shipping weight - lbs. (kg) 1 package		186 (84)	250 (113)	254 (115)

OPTIONAL ACCESSORIES C2A

Compressor Crankcase Heater	90P12	90P12	90P12
Compressor Sound Cover	00000	00000	00000
Hail Guards	11L73	11L74	11L74
Low Ambient Kit - for use with expansion valve systems only	24H77	24H77	24H77
Mounting Base	69J06	69J07	69J07
Timed-Off Control	47J27	47J27	47J27
Unit Stand Off Kit	94J45	94J45	94J45
Compressor Monitor (Optional for Canada Only)	45F08	45F08	45F08

*Variable field

☐ Refrigerant charge sufficient for 20 ft. (6.0 m) length of refrigerant lines.

ELECTRICAL DATA C2A

Model No.		C2A*-24-230	C2A*-30-230	C2A*-36-230	C2A*-42-230	C2A*-48-230	C2A*-60-230
Line voltage data - 60 hz - 1 phase		208/230v	208/230v	208/230v	208/230v	208/230v	208/230v
Rec. max. fuse/circuit breaker size (amps)		20	30	35	40	50	60
☐ Minimum circuit ampacity		14.0	18.0	20.4	24.4	31.5	38.0
Compressor	Rated load amps	10.3	13.5	15.4	18.0	23.7	28.9
	Locked rotor amps	56.0	72.5	88.0	104.0	129.0	169.0
	Power factor	.96	.96	.96	.95	.96	.96
Condenser Coil Fan Motor	Full load amps	1.1	1.1	1.1	1.9	1.9	1.9
	Locked rotor amps	1.9	1.9	1.9	4.1	4.1	4.1

*Variable Field.

☐ Refer to National or Canadian Electrical Code manual to determine wire, fuse and disconnect size requirements.

NOTE — Extremes of operating range are plus 10% and minus 5% of line voltage.

I - UNIT INFORMATION

C0A condensing units are available in 1-1/2, 2, 2 -1/2, 3, 3 -1/2, 4 and 5 ton capacities. C2A condensing units are available in 2, 2-1/2, 3, 3-1/2, 4 and 5 ton capacities.

All major components (indoor blower and coil) must be matched according to recommendations for the compressor to be covered under warranty. Refer to the Engineering Handbook for approved system matchups. A misapplied system will cause erratic operation and can result in early compressor failure.

II - UNIT COMPONENTS

C0A unit components are illustrated in figure 1. C2A components are illustrated in figure 2.

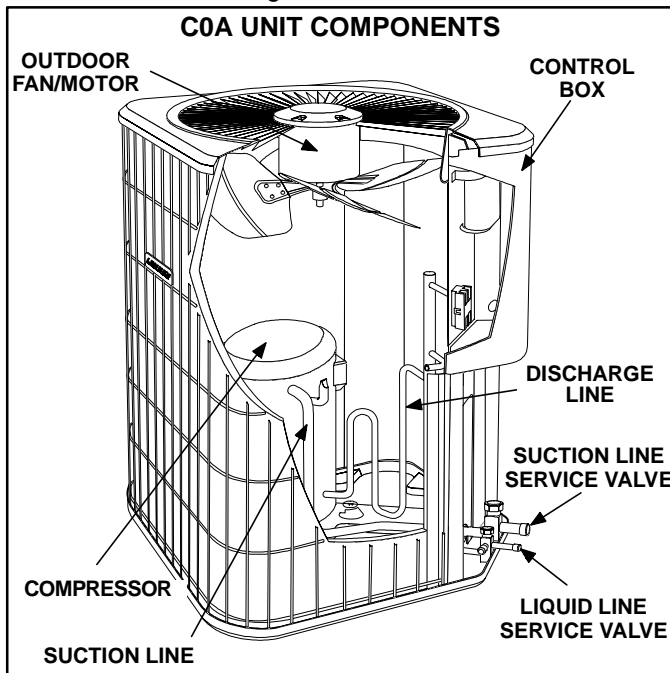

FIGURE 1

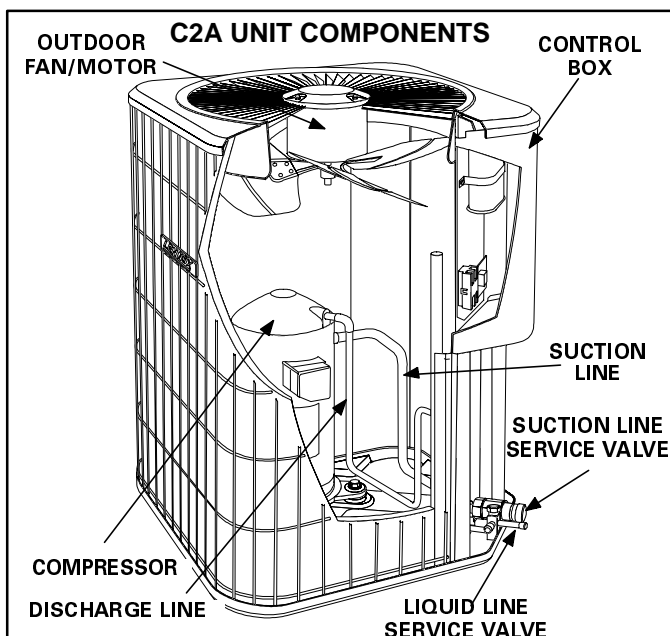

FIGURE 2

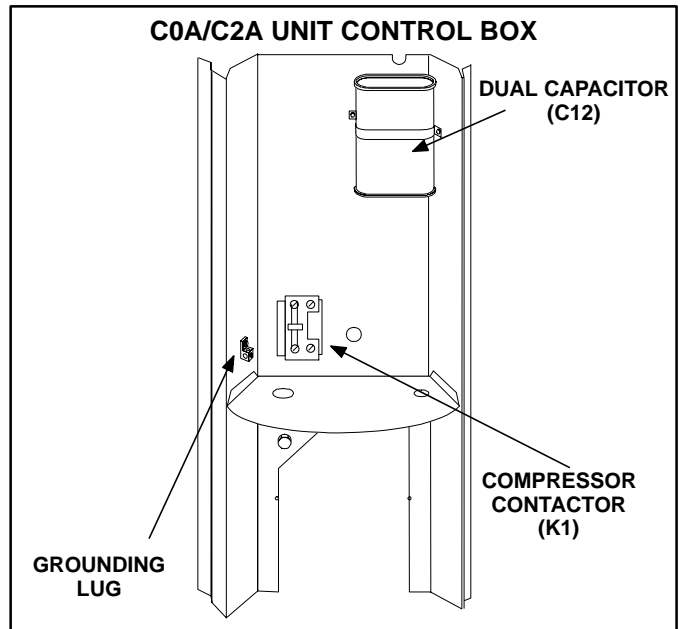

FIGURE 3

A - Control Box (Figure 3)

Electrical openings are provided under the control box cover. Field thermostat wiring is made to color-coded pigtail connections.

1 - Compressor Contactor K1

The compressor is energized by a contactor located in the control box. See figure 3. Single-pole contactors are used in all C0A/C2A series units. K1 is energized by the indoor thermostat terminal Y1 (24V) when thermostat demand is present. C0A/C2A units are not equipped with a 24 volt transformer. All 24 volt controls are powered by the indoor unit.

2 - Dual Capacitor C12

The compressor and fan in C0A/C2A series units use permanent split capacitor motors. The capacitor is located inside the unit control box (see figure 3). A single "dual" capacitor (C12) is used for both the fan motor and the compressor (see unit wiring diagram). The fan side and the compressor side of the capacitor have different MFD ratings. Capacitor ratings may change with compressor.

B - Compressor

All C0A 1-1/2 to 3 ton units utilize a conventional reciprocating compressor. C0A 3-1/2 to 5 ton units use scrolls. See Electrical Data section for compressor specifications.

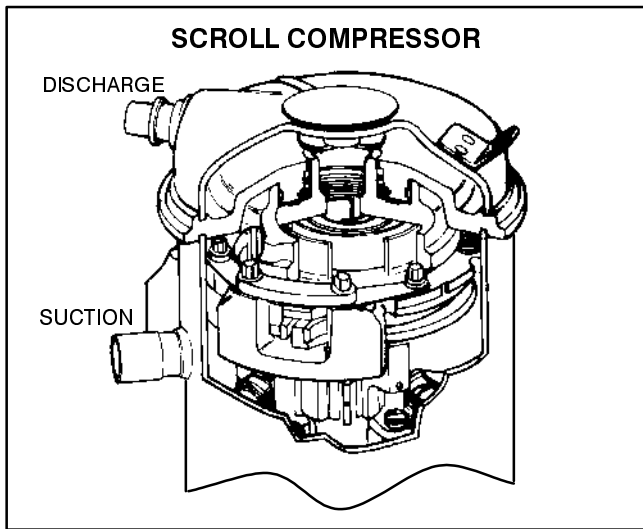

FIGURE 4

All C2A units utilize a scroll compressor. The scroll compressor design is simple, efficient and requires few moving parts. A cutaway diagram of the scroll compressor is shown in figure 4. The scrolls are located in the top of the compressor can and the motor is located just below. The oil level is immediately below the motor.

The scroll is a simple compression concept centered around the unique spiral shape of the scroll and its inherent properties. Figure 5 shows the basic scroll form. Two identical scrolls are mated together forming concentric spiral shapes (figure 6). One scroll remains stationary, while the other is allowed to "orbit" (figure 7). Note that the orbiting scroll does not rotate or turn but merely orbits the stationary scroll.

NOTE - During operation, the head of a scroll compressor may be hot since it is in constant contact with discharge gas.

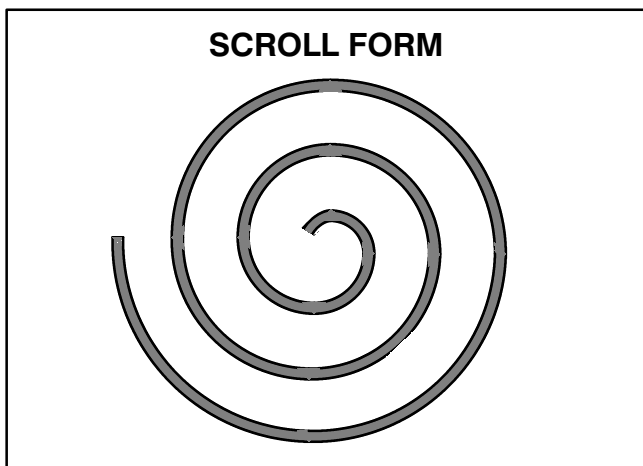

FIGURE 5

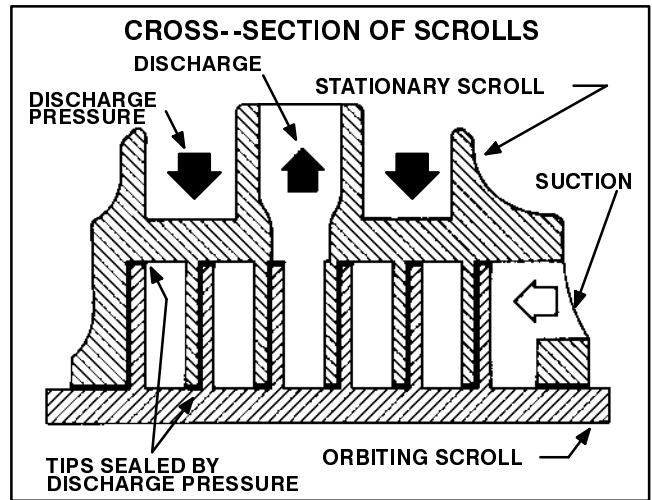

FIGURE 6

The counterclockwise orbiting scroll draws gas into the outer crescent shaped gas pocket created by the two scrolls (figure 7 - 1). The centrifugal action of the orbiting scroll seals off the flanks of the scrolls (figure 7 - 2). As the orbiting motion continues, the gas is forced toward the center of the scroll and the gas pocket becomes compressed (figure 7 - 3). When the compressed gas reaches the center, it is discharged vertically into a chamber and discharge port in the top of the compressor (figure 6). The discharge pressure forcing down on the top scroll helps seal off the upper and lower edges (tips) of the scrolls (figure 6). During a single orbit, several pockets of gas are compressed simultaneously providing smooth continuous compression.

The scroll compressor is tolerant to the effects of liquid return. If liquid enters the scrolls, the orbiting scroll is allowed to separate from the stationary scroll. The liquid is worked toward the center of the scroll and is discharged. If the compressor is replaced, conventional Lennox cleanup practices must be used.

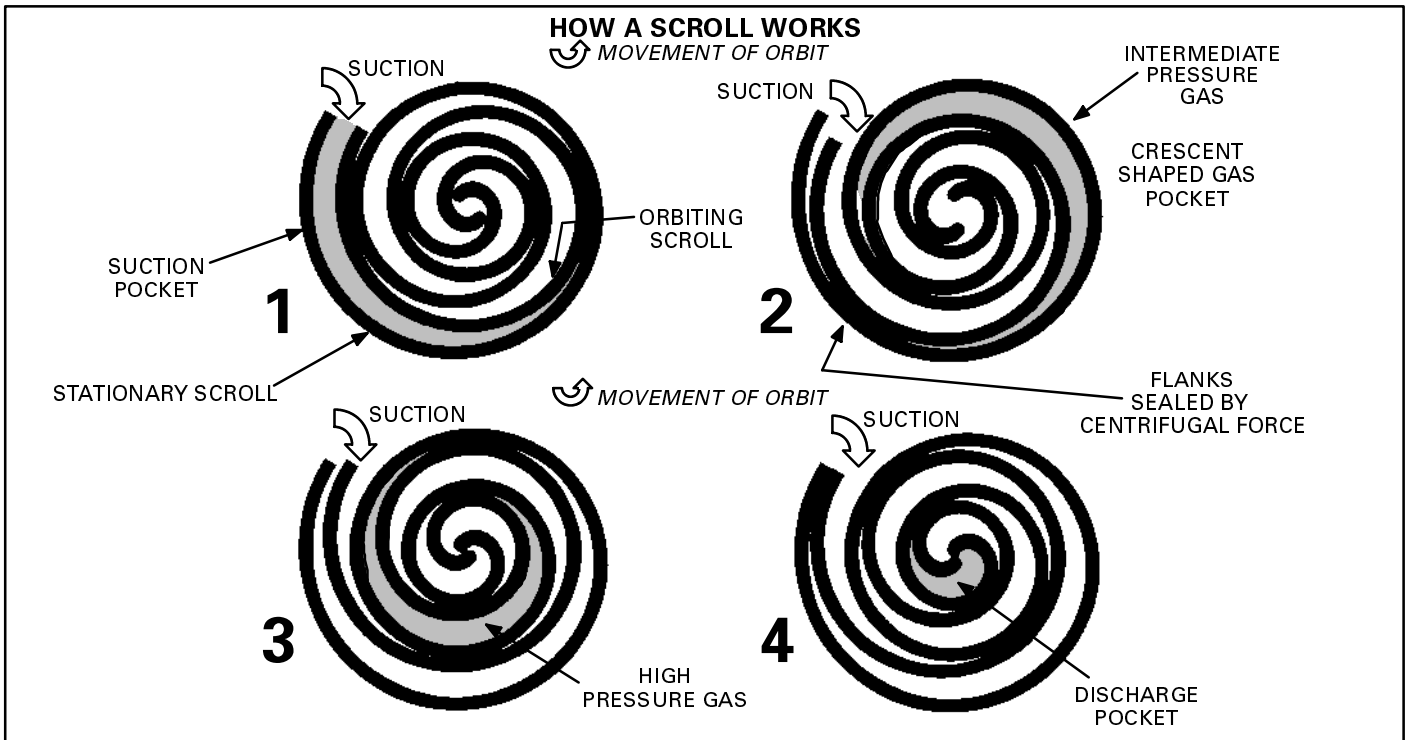

FIGURE 7

Due to its efficiency, the scroll compressor is capable of drawing a much deeper vacuum than reciprocating compressors. Deep vacuum operation can cause internal fusite arcing resulting in damaged internal parts and will result in compressor failure. Never use a scroll compressor for evacuating or “pumping-down” the system. This type of damage can be detected and will result in denial of warranty claims.

The scroll compressor is quieter than a reciprocating compressor, however, the two compressors have much different sound characteristics. The sounds made by a scroll compressor do not affect system reliability, performance, or indicate damage.

See Electrical section for scroll compressor specifications.

C - Condenser Fan Motor

All C0A/C2A units use single-phase PSC fan motors which require a run capacitor. In all units, the condenser fan is controlled by the compressor contactor.

ELECTRICAL DATA tables in this manual show specifications for condenser fans used in C0A/C2As.

Access to the condenser fan motor on all units is gained by removing the seven screws securing the fan assembly. See figure 8. The condenser fan motor is removed from the fan guard by removing the four nuts found on the top panel.

⚠ DANGER

Make sure all power is disconnected before beginning electrical service procedures.

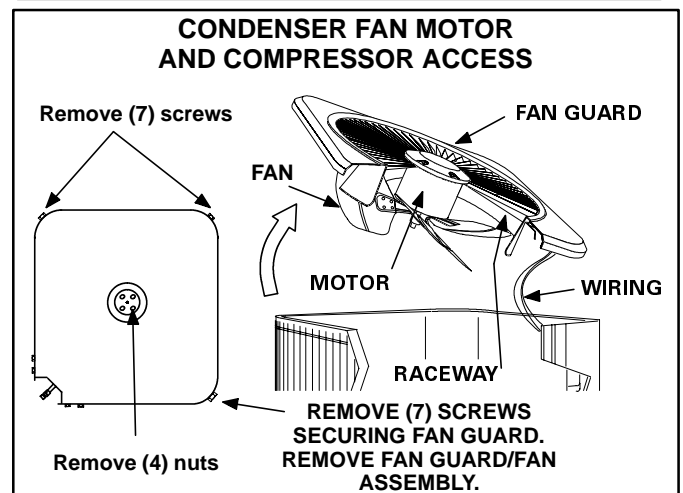

FIGURE 8

III - REFRIGERANT SYSTEM

A - Plumbing

Field refrigerant piping consists of liquid and suction lines from the condensing unit (sweat connections) to the indoor evaporator coil (flare or sweat connections). Use L10 (flare) or L15 (sweat, non-flare) series line sets as shown in tables 1 or 2 or use field-fabricated refrigerant lines. Separate discharge and suction service ports are provided outside the unit for connection of gauge manifold during charging procedure.

TABLE 1

Condensing Unit Model No.	Line Set Model No. (L10 or L15)	Length of Lines		Liquid Line Outside Dia.		Suction Line Outside Dia.	
		ft.	m	in.	mm	in.	mm
C0A-18 C0A-24	L10/15-21-20	20	6	5/16	7.9	5/8	15.9
	L10/15-21-25	25	8				
	L10/15-21-35	35	11				
	L10/15-21-50	50	15				
C0A-30	L15-31-20	20	6	5/16	7.9	3/4	19
	L15-31-30	30	9				
	L15-31-40	40	12				
	L15-31-50	50	15				
C0A-36	L10/15-41-20	20	6	3/8	9.5	3/4	19
	L10/15-41-30	30	9				
	L10/15-41-40	40	12				
	L10/15-41-50	50	15				
C0A-42 C0A-48	L10/15-65-30	30	9	3/8	9.5	7/8	22.2
	L10/15-65-40	40	12				
	L10/15-65-50	50	15				
C0A60	*Field fabricate			3/8	9.5	1-1/8	28.5

*Field fabricate.

TABLE 2

Condensing Unit Model No.	Line Set Model No. (L10 or L15)	Length of Lines		Liquid Line Outside Dia.		Suction Line Outside Dia.	
		ft.	m	in.	mm	in.	mm
C2A-24 C2A-30	L10-41-20 L15-41-20	20	6	3/8	9.5	3/4	19
	L10-41-30 L15-41-30	30	9				
	L10-41-40 L15-41-40	40	12				
	L10-41-50 L15-41-50	50	15				
C2A-36 C2A-42 C2A-48	L10-65-30 L15-65-30	30	9	3/8	9.5	7/8	22.2
	L10-65-40 L15-65-40	40	12				
	L10-65-50 L15-65-50	50	15				
C2A60	*Not available			3/8	9.5	1-1/8	28.5

*Field fabricate.

B - Service Valves

The liquid and suction line service valves (figures 9, 10 and 11) and gauge ports are accessible from outside the unit.

The valve is equipped with a service port. The service ports are used for leak testing, evacuating, charging and checking charge. A schrader valve is factory installed. A service port cap is supplied to protect the schrader valve from contamination and serve as the primary leak seal.

NOTE-Always keep valve stem caps clean.

To Access Schrader Port:

- 1 - Remove service port cap with an adjustable wrench.
- 2 - Connect gauge to the service port.
- 3 - When testing is completed, replace service port cap. Tighten finger tight, then an additional 1/6 turn.

To Open Liquid or Suction Line Service Valve:

- 1 - Remove stem cap with an adjustable wrench.
- 2 - Using service wrench and hex head extension (5/16" for suction line and 3/16" for liquid line) back the stem out counterclockwise until the valve stem just touches the retaining ring.
- 3 - Replace stem cap tighten firmly. Tighten finger tight, then tighten an additional 1/6 turn.

⚠ DANGER

Do not attempt to backseat this valve. Attempts to backseat this valve will cause snap ring to explode from valve body under pressure of refrigerant. Personal injury and unit damage will result.

To Close Liquid or Suction Line Service Valve:

- 1 - Remove stem cap with an adjustable wrench.
- 2 - Using service wrench and hex head extension (5/16" for suction line and 3/16" for liquid line), turn stem clockwise to seat the valve. Tighten firmly.
- 3 - Replace stem cap. Tighten finger tight, then tighten an additional 1/6 turn.

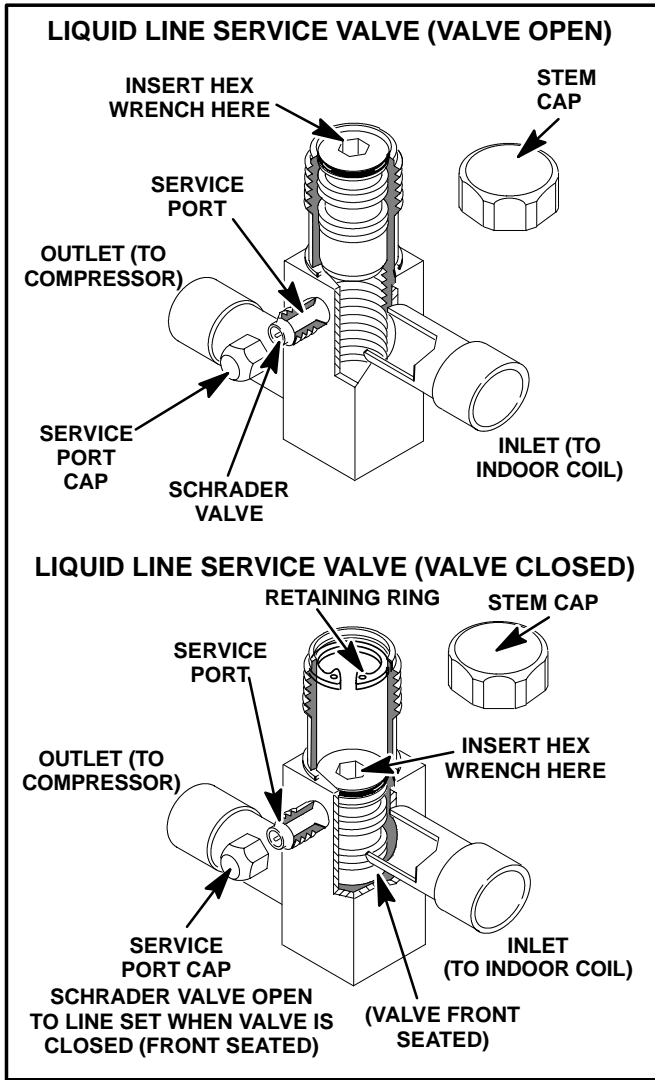

FIGURE 9

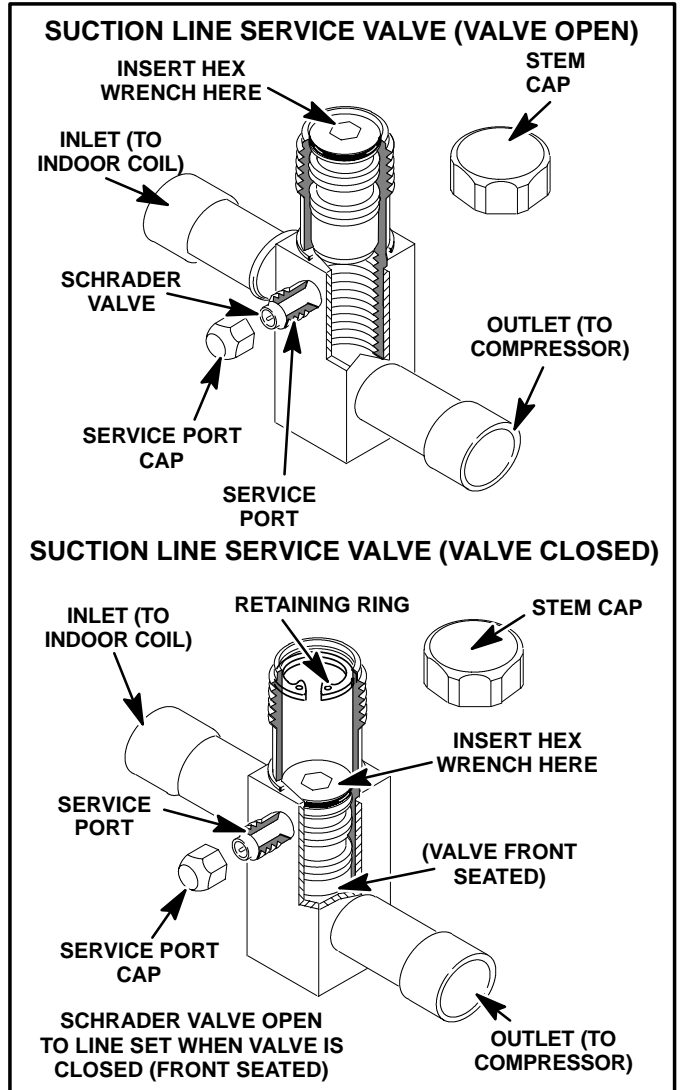

FIGURE 10

**Suction Line (Ball Type) Service Valve
(C0A 5 Ton and all C2A Units)**

A ball-type full service valve is used on all C2A model units and C0A 5 ton units. These suction line service valves function the same way, differences are in construction. Valves are not rebuildable. If a valve has failed it must be replaced. A ball valve is illustrated in figure 11.

The ball valve is equipped with a service port. A schrader valve is factory installed. A service port cap is supplied to protect the schrader valve from contamination and assure a leak free seal.

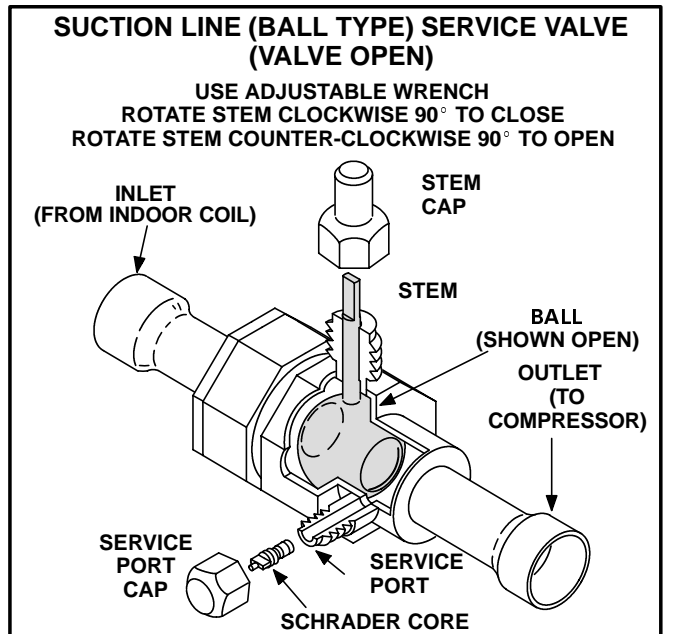

FIGURE 11

IV - CHARGING

The unit is factory-charged with the amount of R-22 refrigerant indicated on the unit rating plate. This charge is based on a matching indoor coil and outdoor coil with a 20 foot (6.1 m) line set. For varying lengths of line set, refer to table 3 for refrigerant charge adjustment. A blank space is provided on the unit rating plate to list actual field charge.

TABLE 3

LIQUID LINE SET DIAMETER	Ounce per 5 foot (ml. per mm) adjust from 20 foot (6.1 m) line set*
1/4 in. (6 mm)	1 ounce per 5 feet (30 ml per 1524 mm)
5/16 in. (8mm)	2 ounce per 5 feet (60 ml per 1524 mm)
3/8 in. (10 mm)	3 ounce per 5 feet (90 ml per 1524 mm)

*If line set is greater than 20 ft. (6.1 m) add this amount. If line set is less than 20 feet (6.1 m) subtract this amount

Units are designed for line sets up to 50 ft (15.2 m). Consult Lennox Refrigerant Piping Manual for line sets over 50 ft (15.2 m).

! IMPORTANT

If line length is greater than 20 feet (6.1 m) add this amount. If line length is less than 20 feet (6.1 m), subtract this amount.

A - Pumping Down System

! CAUTION

Deep vacuum operation (operating compressor at 0 psig or lower) can cause internal fusite arcing resulting in a damaged or failed compressor. This type of damage will result in denial of warranty claim.

The system may be pumped down when leak checking the line set and indoor coil or making repairs to the line set or indoor coil.

- 1- Attach gauge manifold.
- 2- Front seat (close) liquid line valve.
- 3- Start outdoor unit.
- 4- Monitor suction gauge. Stop unit when 0 psig is reached.
- 5- Front seat (close) suction line valve.

B - Leak Testing (To Be Done Before Evacuating)

- 1- Attach gauge manifold and connect a drum of dry nitrogen to center port of gauge manifold.
- 2- Open high pressure valve on gauge manifold and pressurize line set and indoor coil to 150 psig (1034 kPa).
- 3- Check lines and connections for leaks.

NOTE-If electronic leak or Halide detector is used, add a small amount of R-22 (3 to 5 psig [20kPa to 34kPa]) then pressurize with nitrogen to 150 psig.

- 4- Release nitrogen pressure from the system, correct any leaks and recheck.

! CAUTION

When using dry nitrogen, a pressure reducing regulator must be used to prevent excessive pressure in gauge manifold, connecting hoses, and within the system. Regulator setting must not exceed 150 psig (1034 kpa). Failure to use a regulator can cause equipment failure resulting in injury.

C - Evacuating the System

- 1- Attach gauge manifold. Connect vacuum pump (with vacuum gauge) to center port of gauge manifold. With both manifold service valves open, start pump and evacuate indoor coil and refrigerant lines.

! IMPORTANT

A temperature vacuum gauge, mercury vacuum (U-tube), or thermocouple gauge should be used. The usual Bourdon tube gauges are not accurate enough in the vacuum range.

! IMPORTANT

The compressor should never be used to evacuate a refrigeration or air conditioning system.

- 2- Evacuate the system to 29 inches (737mm) vacuum. During the early stages of evacuation, it is desirable to stop the vacuum pump at least once to determine if there is a rapid loss of vacuum. A rapid loss of vacuum would indicate a leak in the system and a repeat of the leak testing section would be necessary.
- 3- After system has been evacuated to 29 inches (737mm), close gauge manifold valves to center port, stop vacuum pump and disconnect from gauge manifold. Attach an upright nitrogen drum to center port of gauge manifold and open drum valve slightly to purge line at manifold. Break vacuum in system with nitrogen pressure by opening manifold high pressure valve. Close manifold high pressure valve to center port.
- 4- Close nitrogen drum valve and disconnect from gauge manifold center port. Release nitrogen pressure from system.
- 5- Connect vacuum pump to gauge manifold center port. Evacuate system through manifold service valves until vacuum in system does not rise above .5mm of mercury absolute pressure or 500 microns within a 20-minute period after stopping vacuum pump.
- 6- After evacuation is complete, close manifold center port, and connect refrigerant drum. Pressurize system slightly with refrigerant to break vacuum.

D - Charging

If the system is completely void of refrigerant, the recommended and most accurate method of charging is to weigh the refrigerant into the unit according to the total amount shown on the unit nameplate. Also refer to the tables in the SPECIFICATIONS section of this manual.

If weighing facilities are not available or if unit is just low on charge, the following procedure applies.

1 - Expansion Valve Systems

The following procedures are intended as a general guide for use with expansion valve systems only. For best results, indoor temperature should be between 70°F and 80°F (21.1°C and 26.7°C). Outdoor temperature should be 60°F (15.6°C) or above. Slight variations in charging temperature and pressure should be expected. Large variations may indicate need for further servicing.

⚠ IMPORTANT

The following procedure requires accurate readings of ambient (outdoor) temperature, liquid temperature and liquid pressure for proper charging. Use a thermometer with accuracy of $\pm 2^\circ\text{F}$ ($\pm 1.1^\circ\text{C}$) and a pressure gauge with accuracy of ± 5 PSIG (± 34.5 kPa).

APPROACH METHOD (TXV SYSTEMS)

(Ambient Temperature of 60°F [16°C] or Above)

- 1 - Connect gauge manifold. Connect an upright R-22 drum to center port of gauge manifold.
- 2 - Record outdoor air (ambient) temperature.
- 3 - Operate indoor and outdoor units in cooling mode. Allow outdoor unit to run until system pressures stabilize.
- 4 - Make sure thermometer well is filled with mineral oil before checking liquid line temperature.
- 5 - Place thermometer in well and read liquid line temperature. Liquid line temperature should be warmer than the outdoor air temperature. Tables 4 and 5 shows how many degrees warmer the liquid line temperature should be.

Add refrigerant to lower the liquid line temperature.

Recover refrigerant to raise the liquid line temperature.

Add refrigerant slowly as the unit approaches the correct temperature. This will allow refrigerant to stabilize allowing the correct temperature to be read.

**TABLE 4
COA**

Model Number	Approach Temperature	
	Liquid Line °F (°C)	- Outdoor Temperature °F (°C)
C0A-18	4 (2.2)	
C0A-24	5 (2.8)	
C0A-30	10 (5.6)	
C0A-36	12 (6.7)	
C0A-42	12 (6.7)	
C0A-48	13 (7.2)	
C0A-60	13 (7.2)	

Note-For best results, the same electronic thermometer should be used to check both outdoor and liquid temperatures.

- 6 - When unit is properly charged, liquid line pressures should approximate those in tables 6, and 7.

⚠ IMPORTANT

Use tables 6 and 7 as a general guide for performing maintenance checks. Tables 6 and 7 are not a procedure for charging the system. Minor variations in these pressures may be expected due to differences in installations. Significant deviations could mean that the system is not properly charged or that a problem exists with some component in the system. Used prudently, tables 6 and 7 could serve as a useful service guide.

**TABLE 5
C2A**

Model	APPROACH TEMPERATURE	
	LIQUID LINE ° F	- OUTDOOR AMBIENT ° F
C2A-24	10°F (5.5°C)	
C2A-30	8°F (4.4°C)	
C2A-36	7°F (3.8°C)	
C2A-42	8°F (4.4°C)	

**TABLE 6
COA Model Units**

OUTDOOR COIL ENTERING AIR TEMPERATURE	NORMAL OPERATING PRESSURES*													
	C0A-18		C0A-24		C0A-30		C0A-36		C0A-42		C0A-48		C0A-60	
	LIQ. ± 10 PSIG	SUC. ± 10 PSIG	LIQ. ± 10 PSIG	SUC. ± 10 PSIG	LIQ. ± 10 PSIG	SUC. ± 10 PSIG	LIQ. ± 10 PSIG	SUC. ± 10 PSIG	LIQ. ± 10 PSIG	SUC. ± 10 PSIG	LIQ. ± 10 PSIG	SUC. ± 10 PSIG	LIQ. ± 10 PSIG	SUC. ± 10 PSIG
65°F (18.3°C) (RFCIV)	155	65	160	65	168	63	176	62	174	64	181	65	---	---
75°F (23.9°C) (RFCIV)	181	70	188	70	197	68	203	66	205	69	208	70	---	---
85°F (29.4°C) (RFCIV)	208	75	216	74	227	73	233	70	236	73	239	75	---	---
95°F (35.0°C) (RFCIV)	238	80	247	78	258	77	266	74	271	77	271	79	---	---
105°F (40.6°C) (RFCIV)	270	84	280	82	292	80	299	77	305	80	306	82	---	---
65°F (18.3°C) (TXV)	159	73	164	71	173	71	179	68	180	71	187	73	174	70
75°F (23.9°C) (TXV)	183	75	189	73	199	73	205	70	208	73	212	75	203	72
85°F (31.2°C) (TXV)	209	77	217	75	228	75	235	72	238	75	241	77	235	74
95°F (31.2°C) (TXV)	238	80	247	78	258	77	266	74	271	77	271	79	269	76
105°F (31.2°C) (TXV)	269	82	279	80	292	79	299	77	305	79	305	80	306	78

*These are typical pressures only. Indoor evaporator match up, indoor air quality and evaporator load will cause the pressures to vary.

**TABLE 7
C2A Model Units**

NORMAL OPERATING PRESSURES*								
OUTDOOR COIL ENTERING AIR TEMPERATURE	C2A-24		C2A-30		C2A-36		C2A-42	
	LIQ. ±10 PSIG	SUC. ± 10 PSIG	LIQ. ±10 PSIG	SUC. ± 10 PSIG	LIQ. ±10 PSIG	SUC. ± 10 PSIG	LIQ. ±10 PSIG	SUC. ± 10 PSIG
82°F (47.2°C)	187	77	180	72	190	73	187	79
95°F (52.8°C)	226	79	219	74	229	75	229	80

*These are typical pressures only. Indoor evaporator match up, indoor air quality and evaporator load will cause the pressures to vary.

2 - RFCIV Systems

The following procedures are intended as a general guide for use with RFCIV systems only. For best results, indoor temperature should be between 70°F and 80°F (21.1°C and 26.7°C). Outdoor temperature should be 60°F (15.6°C) or above. Slight variations in charging temperature and pressure should be expected. Large variations may indicate a need for further servicing.

**TABLE 8
C0A Model Units**

Outdoor Temperature °F(°C)	Liquid Subcooling (± 1°F or 0.5 °C)					
	C0A-18	C0A-24	C0A-30	C0A-36	C0A-42	C0A-48
60 (16)	17 (9.5)	18 (10)	18 (10)	14 (8)	16 (8.9)	15 (8.3)
65 (18)	16 (8.9)	16 (8.9)	17 (9.5)	13 (7.8)	15 (8.3)	14 (8)
70 (21)	15 (8.3)	14 (8)	16 (8.9)	12 (6.7)	14 (8)	13 (7.8)
75 (24)	14 (8)	12 (6.7)	15 (8.3)	10 (5.6)	13 (7.8)	11 (6.1)
80 (27)	13 (7.8)	11 (6.1)	14 (8)	9 (5)	12 (6.7)	10 (5.6)
85 (29)	12 (6.7)	10 (5.6)	13 (7.8)	8 (4.4)	11 (6.1)	8 (4.4)
90 (32)	11 (6.1)	9 (5)	12 (6.7)	7 (3.9)	10 (5.6)	7 (3.9)
95 (35)	9 (5)	8 (4.4)	11 (6.1)	6 (3.3)	9 (5)	7 (3.9)
100 (38)	8 (4.4)	7 (3.9)	10 (5.6)	5 (2.8)	8 (4.4)	6 (3.3)
105 (41)	7 (3.9)	6 (3.3)	9 (5)	4 (2.2)	6 (3.3)	4 (2.2)
110 (43)	6 (3.3)	6 (3.3)	7 (3.9)	3 (1.7)	5 (2.8)	3 (1.7)
115 (46)	5 (2.8)	5 (2.8)	5 (2.8)	2 (1.1)	3 (1.7)	2 (1.1)

- 1 - Connect gauge manifold. Connect an upright R-22 drum to center port of gauge manifold.
- 2 - Operate indoor and outdoor units. Allow outdoor unit to run until system pressures stabilize.
- 3 - Make sure thermometer well is filled with mineral oil before checking liquid line temperature.
- 4 - Read liquid line pressure and convert to condensing temperature using temperature/pressure conversion chart.

Condensing temperature (read from gauges) should be warmer than liquid line temperature.

- 5 - Place thermometer in well and read liquid line temperature. Table 8 shows how much warmer the condensing temperature should be.
- 6 - Subtract liquid line temperature from condensing temperature to determine subcooling. Compare with table 8.
Add refrigerant to lower liquid line temperature.
Recover refrigerant to raise liquid line temp.
- 7 - When unit is properly charged liquid line pressures should approximate table 6.

E - Oil Charge

Refer to compressor nameplate.

V - MAINTENANCE

At the beginning of each heating or cooling season, the system should be cleaned as follows:

A - Outdoor Unit

- 1 - Clean and inspect condenser coil. (Coil may be flushed with a water hose).
- 2 - Visually inspect all connecting lines, joints and coils for evidence of oil leaks.

B - Indoor Coil

- 1 - Clean coil if necessary.
- 2 - Check connecting lines and coil for evidence of oil leaks.
- 3 - Check condensate line and clean if necessary.

C - Indoor Unit

- 1 - Clean or change filters.
- 2 - Bearings are pre-lubricated and need no further oiling.
- 3 - Check all wiring for loose connections.
- 4 - Check for correct voltage at unit.
- 5 - Check amp-draw on blower motor.
Unit nameplate _____ Actual _____.

VI - WIRING DIAGRAMS AND SEQUENCE OF OPERATION

C0A 1-1/2 THROUGH 5 TON OPERATING SEQUENCE

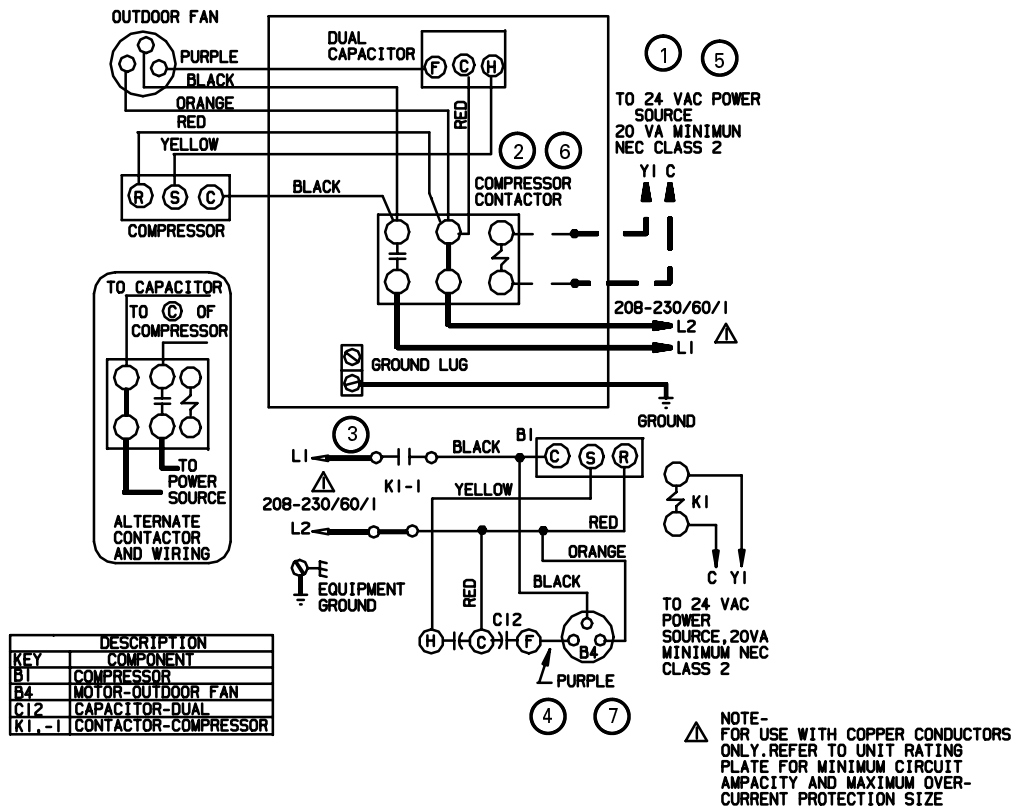

WARNING-
ELECTRIC SHOCK HAZARD, CAN CAUSE INJURY OR DEATH. UNIT MUST BE GROUND IN ACCORDANCE WITH NATIONAL AND LOCAL CODES.

— LINE VOLTAGE FIELD INSTALLED
- - - CLASS 11 VOLTAGE FIELD INSTALLED

WIRING DIAGRAM				3/99
COOLING UNITS-CONDENSING UNITS				
UNIT	REV	UNIT	REV	
COAL-18-230	01	COAL-42-230	01	
COAL-24-230	01	COAL-48-230	01	
COAL-30-230	01	COAL-60-230	01	
COAL-36-230	01			
Supersedes Form No.		New Form No.		
		532,987W		

Litho U.S.A.

A-C0A 1-1/2 - 5 TON OPERATING SEQUENCE

This is the sequence of operation for C0A 1-1/2 through 5 ton units. The sequence is outlined by numbered steps which correspond to circled numbers on the adjacent diagram.

NOTE- The thermostat used may be electromechanical or electronic.

NOTE- Transformer in indoor unit supplies power (24 VAC) to the thermostat and outdoor unit controls.

COOLING:

- 1 - Cooling demand initiates at Y1 in the thermostat.
- 2 - 24VAC energizes compressor contactor K1.
- 3 - K1-1 N.O. closes, energizing compressor (B1) and outdoor fan motor (B4).
- 4 - Compressor (B1) and outdoor fan motor (B4) begin immediate operation.

END OF COOLING DEMAND:

- 5 - Cooling demand is satisfied. Terminal Y1 is de-energized.
- 6 - Compressor contactor K1 is de-energized.
- 7 - K1-1 opens and compressor (B1) and outdoor fan motor (B4) are de-energized and stop immediately.

C2A 2 THROUGH 5 TON OPERATING SEQUENCE

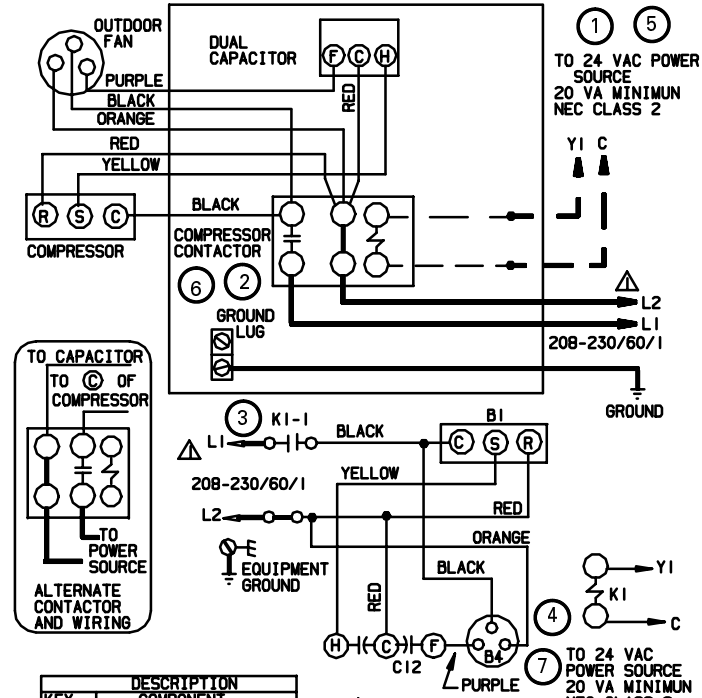

KEY	DESCRIPTION
B1	COMPRESSOR
B4	MOTOR-OUTDOOR FAN
C12	CAPACITOR-DUAL
K1, -1	CONTACTOR-COMPRESSOR

NOTE-
FOR USE WITH COPPER CONDUCTORS
ONLY. REFER TO UNIT RATING
PLATE FOR MINIMUM CIRCUIT
AMPACITY AND MAXIMUM OVER-
CURRENT PROTECTION SIZE

WARNING-
ELECTRIC SHOCK HAZARD, CAN CAUSE INJURY OR
DEATH. UNIT MUST BE GROUND IN ACCORDANCE
WITH NATIONAL AND LOCAL CODES.

— LINE VOLTAGE FIELD INSTALLED
= CLASS II VOLTAGE FIELD INSTALLED

WIRING DIAGRAM			
COOLING UNITS-CONDENSING UNITS			
UNIT	REV	UNIT	REV
C2AL-24-230	01	C2AL-42-230	01
C2AL-30-230	01	C2AL-48-230	01
C2AL-36-230	01	C2AL-60-230	01
Supersedes Form No.		New Form No.	
		532,991W	

Litho U.S.A.

C2A 2 - 5 TON OPERATING SEQUENCE

This is the sequence of operation for C2A 2 through 5 ton units. The sequence is outlined by numbered steps which correspond to circled numbers on the adjacent diagram.

NOTE- The thermostat used may be electromechanical or electronic.

NOTE- Transformer in indoor unit supplies power (24 VAC) to the thermostat and outdoor unit controls.

COOLING:

- 1 - Cooling demand initiates at Y1 in the thermostat.
- 2 - 24VAC from indoor unit (Y1) energizes compressor contactor K1.
- 3 - K1-1 N.O. closes, energizing compressor (B1) and outdoor fan motor (B4).
- 4 - Compressor (B1) and outdoor fan motor (B4) begin immediate operation..

END OF COOLING DEMAND:

- 5 - Cooling demand is satisfied. Terminal Y1 is de-energized.
- 6 - Compressor contactor K1 is de-energized.
- 7 - K1-1 opens and compressor (B1) and outdoor fan motor (B4) are de-energized and stop immediately.